

# Operator's Manual

## Pump PT 2 PT 2A

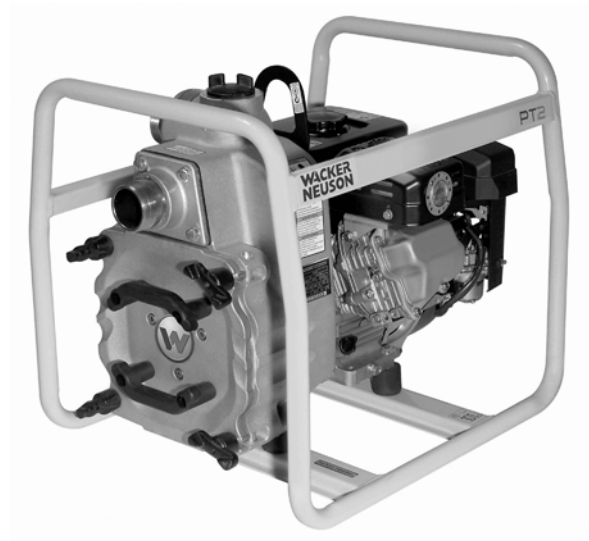

0151719en	009	0810
-----------	-----	------



**Copyright notice**

© Copyright 2010 by Wacker Neuson Corporation.

All rights, including copying and distribution rights, are reserved.

This publication may be photocopied by the original purchaser of the machine. Any other type of reproduction is prohibited without express written permission from Wacker Neuson Corporation.

Any type of reproduction or distribution not authorized by Wacker Neuson Corporation represents an infringement of valid copyrights. Violators will be prosecuted.

---

**Trademarks**

All trademarks referenced in this manual are the property of their respective owners.

---

**Manufacturer**

Wacker Neuson Corporation

N92W15000 Anthony Avenue

Menomonee Falls, WI 53051 U.S.A.

Tel: (262) 255-0500 · Fax: (262) 255-0550 · Tel: (800) 770-0957

[www.wackerneuson.com](http://www.wackerneuson.com)

---

**Translated instructions**

This Operator's Manual presents the original instructions. The original language of this Operator's Manual is American English.

---

## Foreword

### Machines covered in this manual

Machine	Item Number
PT 2	0009318, 0009319, 0009320
PT 2A	0009092, 0009095, 0009237
PT 2(I)	0620725
PT 2V	0009093, 0009096, 0009238
PT 2H	0009094, 0009097, 0009239

### Machine documentation

- Keep a copy of the Operator’s Manual with the machine at all times.
- Use the separate Parts Book supplied with the machine to order replacement parts.
- Refer to the separate Repair Manual for detailed instructions on servicing and repairing the machine.
- If you are missing any of these documents, please contact Wacker Neuson Corporation to order a replacement or visit [www.wackerneuson.com](http://www.wackerneuson.com).
- When ordering parts or requesting service information, be prepared to provide the machine model number, item number, revision number, and serial number.

### Expectations for information in this manual

- This manual provides information and procedures to safely operate and maintain the above Wacker Neuson model(s). For your own safety and to reduce the risk of injury, carefully read, understand, and observe all instructions described in this manual.
- Wacker Neuson Corporation expressly reserves the right to make technical modifications, even without notice, which improve the performance or safety standards of its machines.
- The information contained in this manual is based on machines manufactured up until the time of publication. Wacker Neuson Corporation reserves the right to change any portion of this information without notice.

### CALIFORNIA Proposition 65 Warning

Engine exhaust, some of its constituents, and certain vehicle components, contain or emit chemicals known to the State of California to cause cancer and birth defects or other reproductive harm.

### Laws pertaining to spark arresters

**NOTICE:** State Health Safety Codes and Public Resources Codes specify that in certain locations spark arresters be used on internal combustion engines that use hydrocarbon fuels. A spark arrester is a device designed to prevent accidental discharge of sparks or flames from the engine exhaust. Spark arresters are qualified and rated by the United States Forest Service for this purpose. In order to comply with local laws regarding spark arresters, consult the engine distributor or the local Health and Safety Administrator.

### Manufacturer’s approval

This manual contains references to *approved* parts, attachments, and modifications. The following definitions apply:

- **Approved parts or attachments** are those either manufactured or provided by Wacker Neuson.

- **Approved modifications** are those performed by an authorized Wacker Neuson service center according to written instructions published by Wacker Neuson.
- **Unapproved parts, attachments, and modifications** are those that do not meet the approved criteria.

Unapproved parts, attachments, or modifications may have the following consequences:

- Serious injury hazards to the operator and persons in the work area
- Permanent damage to the machine which will not be covered under warranty

Contact your Wacker Neuson dealer immediately if you have questions about approved or unapproved parts, attachments, or modifications.



<b>1. Safety Information</b>	<b>7</b>
1.1 Signal Words .....	7
1.2 Operation and Intended Use .....	8
1.3 Operating Safety .....	10
1.4 Operator Safety while using Internal Combustion Engines .....	12
1.5 Service Safety .....	13
<b>2. Labels</b>	<b>14</b>
2.1 Label Locations (PT 2A, PT 3A, PT 2, PT 3) .....	14
2.2 Label Locations (PT 2V, PT 3V) .....	15
2.3 Label Locations (PT 2H, PT 3H) .....	16
2.4 Safety Labels .....	17
2.5 Informational Labels .....	19
<b>3. Lifting And Transporting</b>	<b>20</b>
<b>4. Operation</b>	<b>21</b>
4.1 Preparing the Machine for First Use .....	21
4.2 Recommended Fuel (Wacker Neuson / Honda / Vanguard) .....	21
4.3 Recommended Fuel (Hatz) .....	21
4.4 Before Starting .....	22
4.5 To Start (Wacker Neuson) .....	24
4.6 To Stop (Wacker Neuson) .....	24
4.7 To Start (Honda) .....	25
4.8 To Stop (Honda) .....	25
4.9 To Start (Vanguard) .....	26
4.10 To Stop (Vanguard) .....	26
4.11 To Start (Hatz) .....	27
4.12 Cold Weather Starting (Hatz) .....	28
4.13 To Stop (Hatz) .....	28
4.14 Operation .....	28
4.15 Hoses and Clamps .....	29
4.16 Emergency Shutdown Procedure .....	30
<b>5. Maintenance</b>	<b>31</b>
5.1 Periodic Maintenance Schedule .....	31

5.2 Engine Oil System (Hatz) .....32

5.3 Engine Oil (Wacker Neuson / Honda / Vanguard) .....34

5.4 Air Cleaner (Wacker Neuson) .....35

5.5 Air Cleaner (Honda) .....36

5.6 Air Cleaner (Vanguard) .....37

5.7 Air Cleaner (Hatz) .....38

5.8 Spark Plug (Wacker Neuson / Honda / Vanguard) .....39

5.9 Sediment Cup (Honda) .....39

5.10 Cleaning Fuel Strainer (Wacker Neuson) .....40

5.11 Fuel Filter (Vanguard) .....40

5.12 Fuel Filter (Hatz) .....41

5.13 Carburetor (Wacker Neuson / Honda) .....42

5.14 Carburetor (Vanguard) .....43

5.15 Valve Clearances (Hatz) .....44

5.16 Adjusting Impeller Clearance .....46

5.17 Cleaning Pump .....47

5.18 Storage .....48

5.19 Accessories .....48

5.20 Troubleshooting .....49

**6. Technical Data 50**

6.1 Engine .....50

6.2 Pump .....51

6.3 Sound Measurements .....51

## 1 Safety Information

### 1.1 Signal Words

This manual contains **DANGER**, **WARNING**, **CAUTION**, **NOTICE**, and **NOTE** signal words which must be followed to reduce the possibility of personal injury, damage to the equipment, or improper service.



---

This is the safety alert symbol. It is used to alert you to potential personal hazards.

- ▶ Obey all safety messages that follow this symbol.

---



---

#### **DANGER**

**DANGER** indicates a hazardous situation which, if not avoided, will result in death or serious injury.

- ▶ To avoid death or serious injury from this type of hazard, obey all safety messages that follow this signal word.
- 



---

#### **WARNING**

**WARNING** indicates a hazardous situation which, if not avoided, could result in death or serious injury.

- ▶ To avoid possible death or serious injury from this type of hazard, obey all safety messages that follow this signal word.
- 



---

#### **CAUTION**

**CAUTION** indicates a hazardous situation which, if not avoided, could result in minor or moderate injury.

- ▶ To avoid possible minor or moderate injury from this type of hazard, obey all safety messages that follow this signal word.
- 

**NOTICE:** Used without the safety alert symbol, **NOTICE** indicates a situation which, if not avoided, could result in property damage.

**Note:** A Note contains additional information important to a procedure.

## 1.2 Operation and Intended Use

This machine is a centrifugal trash pump. The Wacker Neuson Trash Pump consists of a tubular steel frame surrounding a gasoline or diesel engine, a fuel tank, and an impeller pump with ports for water suction and discharge. The engine rotates the impeller during operation. Waste water is drawn into the pump through the suction port and expelled through the discharge port. The operator connects hoses to the pump and routes them so that water and solids are drained from the work area and discharged into an appropriate location.

This machine is intended to be used for general de-watering applications. This machine is intended for the pumping of clear water, or water containing solids up to the size stated within the product specifications, and up to the flow, head, and suction lift limits also stated within the product specifications.

This machine has been designed and built strictly for the intended use described above. Using the machine for any other purpose could permanently damage the machine or seriously injure the operator or other persons in the area. Machine damage caused by misuse is not covered under warranty.

The following are some examples of misuse:

- Pumping flammable, explosive, or corrosive fluids
- Pumping hot or volatile fluids that result in pump cavitation
- Operating the pump outside of product specifications due to incorrect diameter hoses, incorrect length hoses, other inlet or outlet restrictions, or excessive suction lift or head
- Using the machine as a ladder, support, or work surface
- Using the machine to carry or transport passengers or equipment
- Operating the machine outside of factory specifications
- Operating the machine in a manner inconsistent with all warnings found on the machine and in the Operator's Manual

This machine has been designed and built in accordance with the latest global safety standards. It has been carefully engineered to eliminate hazards as far as practicable and to increase operator safety through protective guards and labeling. However, some risks may remain even after protective measures have been taken. They are called residual risks. On this machine, they may include exposure to:

- Heat, noise, exhaust, and carbon monoxide from the engine
- Fire hazards from improper refueling techniques
- Fuel and its fumes
- Personal injury from improper lifting techniques



- Projectile hazard from discharge
- Crushing hazards from a tipping or falling pump

To protect yourself and others, make sure you thoroughly read and understand the safety information presented in this manual before operating the machine.

## 1.3 Operating Safety

**Notice:** State Health Safety Codes and Public Resources Codes specify that in certain locations spark arresters be used on internal combustion engines that use hydrocarbon fuels. A spark arrester is a device designed to prevent accidental discharge of sparks or flames from the engine exhaust. Spark arresters are qualified and rated by the United States Forest Service for this purpose.

In order to comply with local laws regarding spark arresters, consult the engine distributor or the local Health and Safety Administrator.



Familiarity and proper training are required for the safe operation of the machine. Machines operated improperly or by untrained personnel can be hazardous. Read the operating instructions contained in this manual and the engine manual, and familiarize yourself with the location and proper use of all controls. Inexperienced operators should receive instruction from someone familiar with the machine before being allowed to operate it.

### Operator qualifications

Only trained personnel are permitted to start, operate, and shut down the machine. They also must meet the following qualifications:

- have received instruction on how to properly use the machine
- are familiar with required safety devices

The machine must not be accessed or operated by:

- children
- people impaired by alcohol or drugs

### Personal Protective Equipment (PPE)

Wear the following Personal Protective Equipment (PPE) while operating this machine:

- Close-fitting work clothes that do not hinder movement
- Safety glasses with side shields
- Hearing protection
- Safety-toed footwear

1.3.1 Do not allow anyone to operate this equipment without proper training. People operating this equipment must be familiar with the risks and hazards associated with it.

1.3.2 Do not use accessories or attachments that are not recommended by Wacker Neuson. Damage to equipment and injury to the user may result.

1.3.3 Do not touch the engine or muffler while the engine is on or immediately after it has been turned off. These areas get hot and may cause burns.

- 1.3.4 Do not pump volatile, flammable, or low flash point fluids. These fluids could ignite or explode.
- 1.3.5 Do not pump corrosive chemicals or water containing toxic substances. These fluids could create serious health and environmental hazards. Contact local authorities for assistance.
- 1.3.6 Do not open the priming plug when the pump is hot. Do not loosen or remove inlet or discharge hose fittings when the pump is hot. Hot water inside could be pressurized much like the radiator on an automobile. Allow the pump to cool to the touch before loosening the plug and before loosening or removing the inlet or discharge hose fittings.
- 1.3.7 Do not open pump housing cover while pump is operating, or start pump with the cover off. The rotating impeller inside the pump can cut or sever objects caught in it.
- 1.3.8 Do not block or restrict flow from inlet line or discharge line. Remove kinks from discharge line before starting pump. Operation with a blocked inlet line or discharge line can cause water inside pump to overheat.
- 1.3.9 Be sure operator is familiar with proper safety precautions and operation techniques before using machine.
- 1.3.10 Read, understand, and follow procedures in the Operator's Manual before attempting to operate the machine.
- 1.3.11 Be sure the machine is on a firm, level surface and will not tip, roll, slide, or fall while operating.
- 1.3.12 Close fuel valve on engines equipped with one when machine is not being operated.
- 1.3.13 Store the machine properly when it is not being used. The machine should be stored in a clean, dry location out of the reach of children.
- 1.3.14 Do not pump fluid into an inappropriate location.
- 1.3.15 Do not place hoses where they may become a tripping hazard.
- 1.3.16 Do not operate the pump without the strainer or with an incorrect strainer.
- 1.3.17 Do not transport the machine while it is running.
- 1.3.18 Do not operate the machine with unapproved accessories or attachments.

## 1.4 Operator Safety while using Internal Combustion Engines



### WARNING

Internal combustion engines present special hazards during operation and fueling. Failure to follow the warnings and safety standards could result in severe injury or death.

- ▶ Read and follow the warning instructions in the engine owner's manual and the safety guidelines below.



### DANGER

Asphyxiation hazard. Using a pump indoors CAN KILL YOU IN MINUTES. Pump exhaust contains carbon monoxide. This is a poison you cannot see or smell.

- ▶ NEVER use this pump inside a home or garage, EVEN IF doors and windows are open. Only use OUTSIDE and far away from windows, doors, and vents.
- ▶ NEVER use a pump inside an enclosed area, such as a tunnel or a trench, unless adequate ventilation is provided through such items as exhaust fans or hoses.

### Operating safety

When operating the pump:

- Keep the area around exhaust pipe free of flammable materials.
- Check the fuel lines and the fuel tank for leaks and cracks before starting the engine.

When operating the pump:

- Do not smoke while operating the machine.
- Do not run the machine if fuel leaks are present or the fuel lines are loose.
- Do not run the engine near sparks or open flames.
- Do not touch the engine or muffler while the engine is running or immediately after it has been turned off.
- Do not operate a machine when its fuel cap is loose or missing.
- Do not start the engine if fuel has spilled or a fuel odor is present. Move the machine away from the spill and wipe the machine dry before starting.

### Refueling safety

When refueling the engine:

- Clean up any spilled fuel immediately.
- Refill the fuel tank in a well-ventilated area.
- Replace the fuel tank cap after refueling.

When refueling the engine:

- Do not smoke.

- Do not refuel a hot or running engine.
- Do not refuel the engine near sparks or open flames.
- Do not refuel if the machine is positioned in a truck fitted with a plastic bed liner. Static electricity can ignite the fuel or fuel vapors.

## 1.5 Service Safety



WARNING

A poorly maintained machine can become a safety hazard! In order for the machine to operate safely and properly over a long period of time, periodic maintenance and occasional repairs are necessary.

### Personal Protective Equipment (PPE)

Wear the following Personal Protective Equipment (PPE) while servicing or maintaining this machine:

- Close-fitting work clothes that do not hinder movement
- Safety glasses with side shields
- Hearing protection
- Safety-toed footwear

In addition, before servicing or maintaining the machine:

- Tie back long hair.
- Remove all jewelry (including rings).

**Do not attempt to clean or service the machine while it is running. Rotating parts can cause severe injury.**

- 1.5.1 Do not crank a flooded engine with the spark plug removed on gasoline-powered engines. Fuel trapped in the cylinder will squirt out the spark plug opening.
- 1.5.2 Keep the area around the muffler free of debris such as leaves, paper, cartons, etc. A hot muffler could ignite the debris and start a fire.
- 1.5.3 When replacement parts are required for this machine, use only Wacker Neuson replacement parts or those parts equivalent to the original in all types of specifications, such as physical dimensions, type, strength, and material.
- 1.5.4 Disconnect the spark plug on machines equipped with gasoline engines, before servicing, to avoid accidental start-up.
- 1.5.5 Do not use gasoline or other types of fuels or flammable solvents to clean parts, especially in enclosed areas. Fumes from fuels and solvents can become explosive.
- 1.5.6 Handle impeller carefully. The impeller can develop sharp edges which can cut.
- 1.5.7 Do not tip the machine for cleaning or for any other reason.

2 Labels

2.1 Label Locations (PT 2A, PT 3A, PT 2, PT 3)

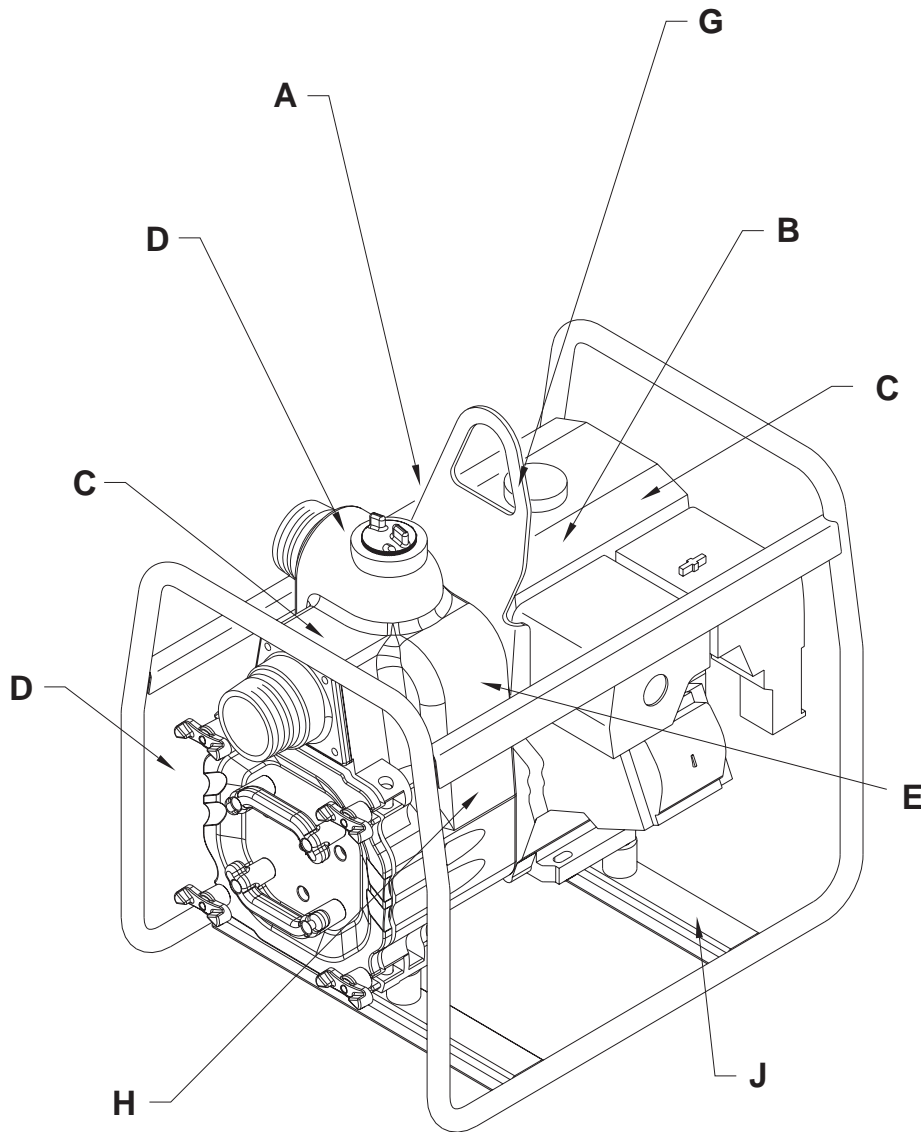

wc\_gr000009

2.2 Label Locations (PT 2V, PT 3V)

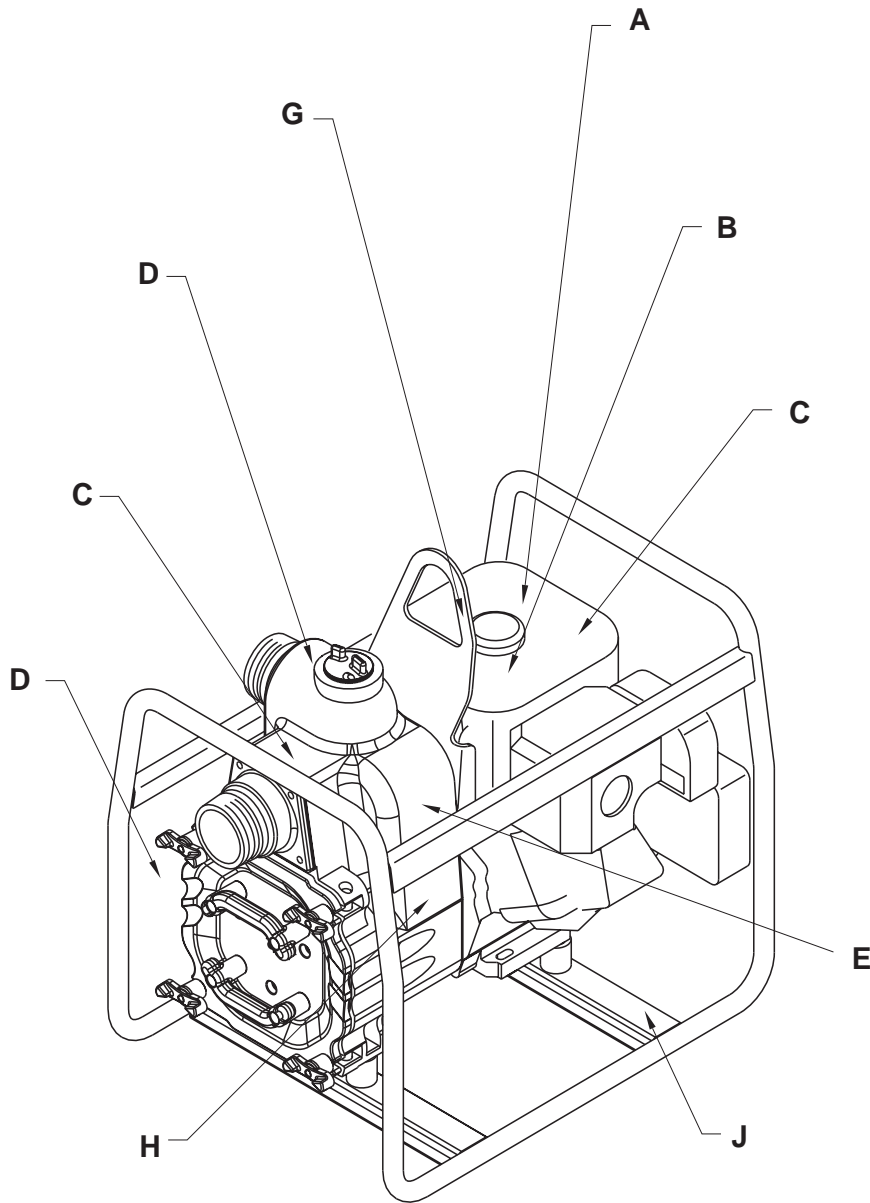

wc\_gr000010

2.3 Label Locations (PT 2H, PT 3H)

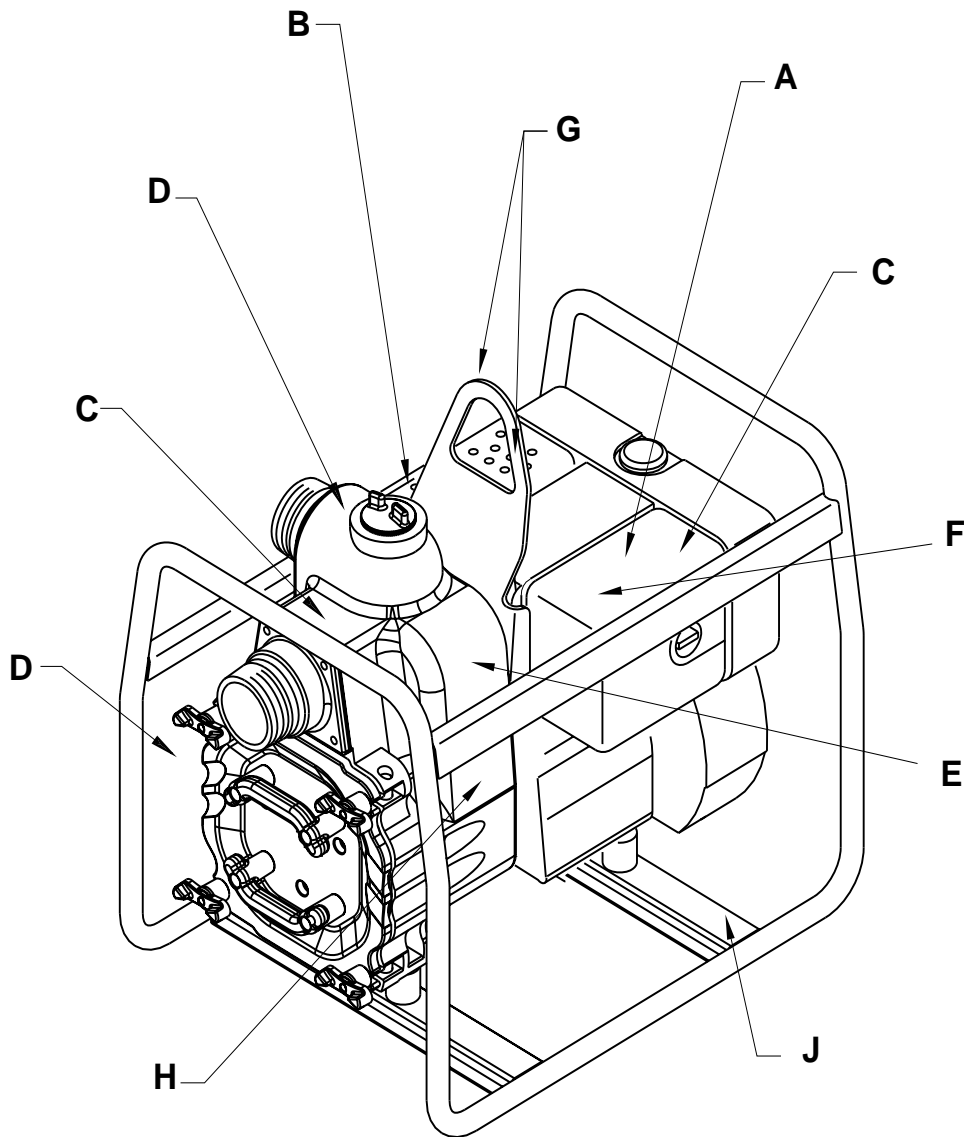







wc\_gr000011





## 2.4 Safety Labels

Wacker Neuson machines use international pictorial labels where needed. These labels are described below.

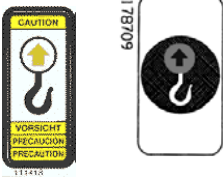
	Label	Meaning
A		<p><b>DANGER!</b> Asphyxiation hazard.</p> <ul style="list-style-type: none"> <li>■ Engines emit carbon monoxide.</li> <li>■ Do not run the machine indoors or in an enclosed area.</li> <li>■ NEVER use inside a home or garage, EVEN IF doors and windows are open.</li> <li>■ Only use OUTSIDE and far away from windows, doors, and vents.</li> <li>■ Read the Operator's Manual.</li> <li>■ No sparks, flames, or burning objects near the machine.</li> <li>■ Stop the engine before refueling.</li> </ul>
B		<p><b>WARNING!</b> Hot surface!</p>
C		<p><b>CAUTION!</b> Read and understand the supplied Operator's Manual before operating this machine. Failure to do so increases the risk of injury to yourself and others.</p>

	Label	Meaning
D	 <p>110164</p> <p>178711</p> <p>178711</p>	<p><b>WARNING!</b> Do not open if pump is hot. Hot water and/ or steam inside could be pressurized.</p>
E	 <p>151049</p> <p>178764</p>	<p><b>WARNING!</b> Never pump volatile, flammable, or low-flash-point fluids. These fluids could ignite or explode.</p>
F	 <p>119679</p> <p>178731</p>	<p><b>CAUTION!</b> Use only clean, filtered diesel fuel.</p>
G	 <p>115448</p> <p>60/BZ1</p>	<p><b>CAUTION</b> Lifting point.</p>

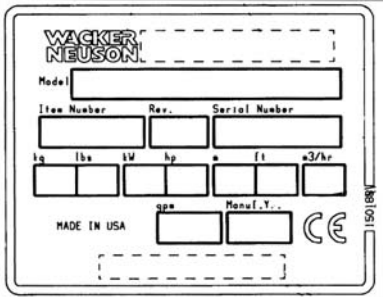
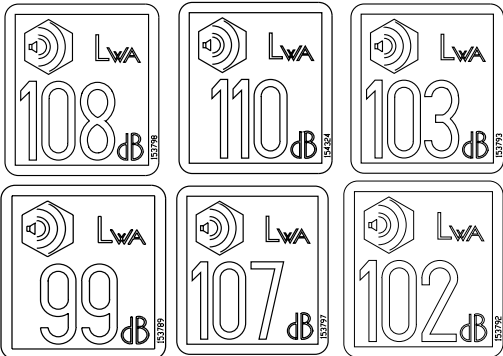
2.5 Informational Labels

	Label	Meaning
H		<p>A nameplate listing the model number, item number, revision number, and serial number is attached to each unit. Please record the information found on this plate so it will be available should the nameplate become lost or damaged. When ordering parts or requesting service information, you will always be asked to specify the model number, item number, revision number, and serial number of the unit.</p>
J		<p>Guaranteed sound power level in dB(A).</p>
—		<p>This machine may be covered by one or more patents.</p>

### **3 Lifting And Transporting**

#### **Lifting the machine**

This pump is heavy enough to cause injury if proper lifting techniques are not used. Observe the following guidelines when lifting the pump.

- Do not attempt to lift the pump unassisted. Use appropriate lifting equipment such as slings, chains, hooks, ramps, or jacks.
- Make sure lifting equipment is attached securely and has enough weight-bearing capacity to lift or hold the pump safely.
- Remain aware of the location of other people nearby when lifting the pump.

#### **Transporting the machine**

Observe the following guidelines when transporting the pump to and from the job site.

- Drain the fuel tank before transporting the pump.
- Ensure that the pump is securely strapped down in the transport vehicle to prevent it from sliding or tipping.
- Do not refuel the pump in or on the transport vehicle. Move the pump to its operating location and then fill the fuel tank.

## 4 Operation

### 4.1 Preparing the Machine for First Use

#### Preparing for first use

To prepare your machine for first use:

- 4.1.1 Make sure all loose packaging materials have been removed from the machine.
- 4.1.2 Check the machine and its components for damage. If there is visible damage, do not operate the machine! Contact your Wacker Neuson dealer immediately for assistance.
- 4.1.3 Take inventory of all items included with the machine and verify that all loose components and fasteners are accounted for.
- 4.1.4 Attach component parts not already attached.
- 4.1.5 Add fluids as needed and applicable, including fuel, engine oil, and battery acid.
- 4.1.6 Move the machine to its operating location.

### 4.2 Recommended Fuel (Wacker Neuson / Honda / Vanguard)

The engine requires regular grade unleaded gasoline. Use only fresh, clean gasoline. Gasoline containing water or dirt will damage fuel system. Consult engine owner's manual for complete fuel specifications.

### 4.3 Recommended Fuel (Hatz)

The engine requires No. 2 diesel fuel. Use only fresh, clean fuel. Fuel containing water or dirt will damage the fuel system. Consult the engine owner's manual for complete fuel specifications.

## 4.4 Before Starting

See Graphic: wc\_gr000013

- 4.4.1 Read safety instructions at the beginning of this Operator's Manual.
- 4.4.2 Place pump as near to water as possible, on a firm, flat, level surface.
- 4.4.3 To prime pump, remove prime plug **(a)** and fill pump housing with water. If the pump housing is not filled with water before starting, it will not begin pumping.



**WARNING**

Do not open priming plug, discharge plug, or loosen hose fittings if pump is hot! Water or vapor inside pump may be under pressure.

- 4.4.4 Check for leaks between pump and engine. If water is leaking, the seal inside pump is worn or damaged. Continued operation may cause water damage to engine.
- 4.4.5 Check that hoses are securely attached to pump. Suction hose **(b)** must not have any air leaks. Tighten hose clamps **(c)** and couplings **(d)**. Check that discharge hose **(e)** is not restricted. Lay hose out as straight as possible. Remove any twists or sharp bends from hose which may block the flow of water.
- 4.4.6 Make sure suction strainer **(f)** is clean and securely attached to end of hose. The strainer is designed to protect the pump by preventing large objects from being pulled into the pump.  
**NOTICE:** Strainer should be positioned so it will remain completely under water. Running the pump with the strainer above water for long periods can damage the pump.
- 4.4.7 Check fuel level, engine oil level, and condition of air cleaner.

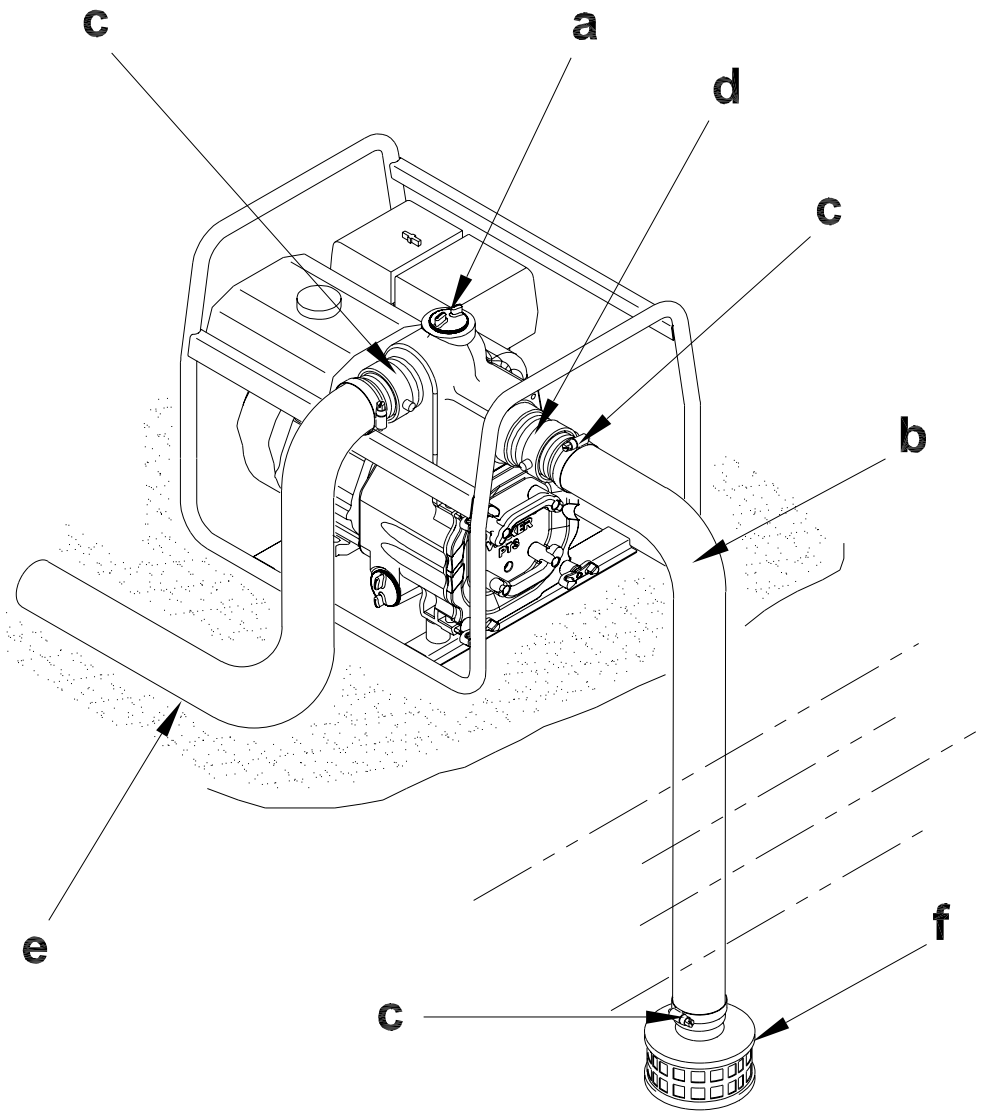

wc\_gr000013

## 4.5 To Start (Wacker Neuson)

See Graphic: *wc\_gr000655*

4.5.1 Open fuel valve by moving lever down (**a1**).

**Note:** *If engine is cold, move choke lever to close position (d2). If engine is hot, set choke to open position (d1).*

4.5.2 Turn engine switch to "ON" (**b2**).

4.5.3 Open throttle by moving it slightly to left (**c2**).

4.5.4 Pull starter rope (**e**).

**Note:** *If the oil level in the engine is low, the engine will not start. If this happens, add oil to engine.*

4.5.5 Open choke as engine warms (**d1**).

4.5.6 Open throttle fully to operate (**c1**).

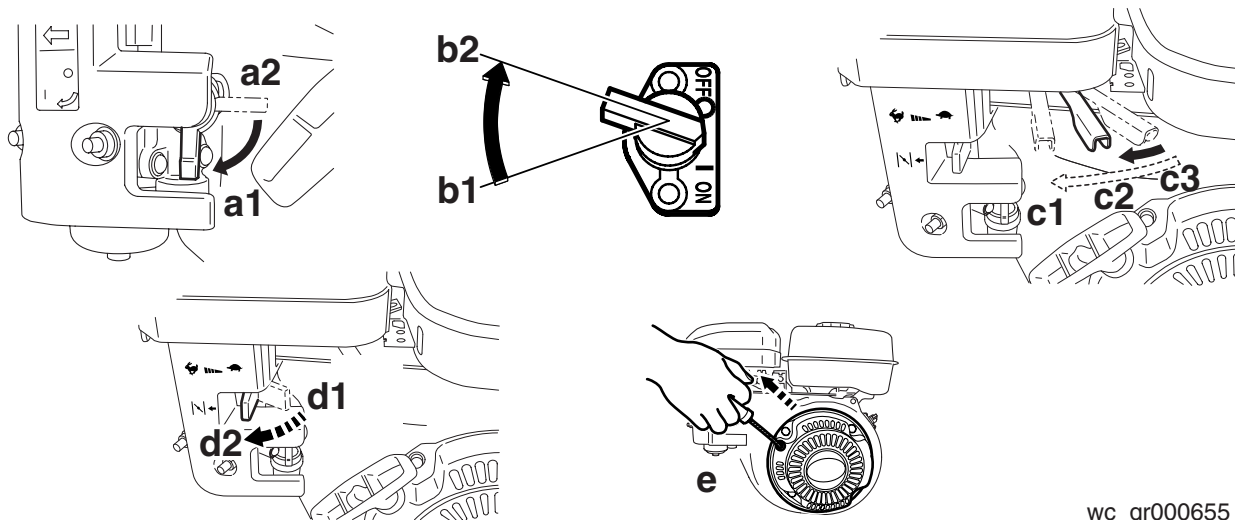

wc\_gr000655

## 4.6 To Stop (Wacker Neuson)

See Graphic: *wc\_gr000655*

4.6.1 Reduce engine RPM to idle by moving throttle completely to right (**c3**).

4.6.2 Turn engine switch to "OFF" (**b1**).

4.6.3 Close fuel valve (**a2**).



## 4.7 To Start (Honda)

See Graphic: wc\_gr000014

4.7.1 Open fuel valve by moving lever to the right (**a1**).

**Note:** If engine is cold, move choke lever to close position (**b1**). If engine is hot, set choke to open position (**b2**).

4.7.2 Turn engine switch to "ON" (**e1**).

4.7.3 Open throttle by moving it slightly to left (**d1**).

4.7.4 Pull starter rope (**c**).

**Note:** If the oil level in the engine is low, the engine will not start. If this happens, add oil to engine. Some engines are equipped with an oil alert light (**f**) that will come on while pulling the starter rope.

4.7.5 Open choke as engine warms (**b2**).

4.7.6 Open throttle fully to operate.

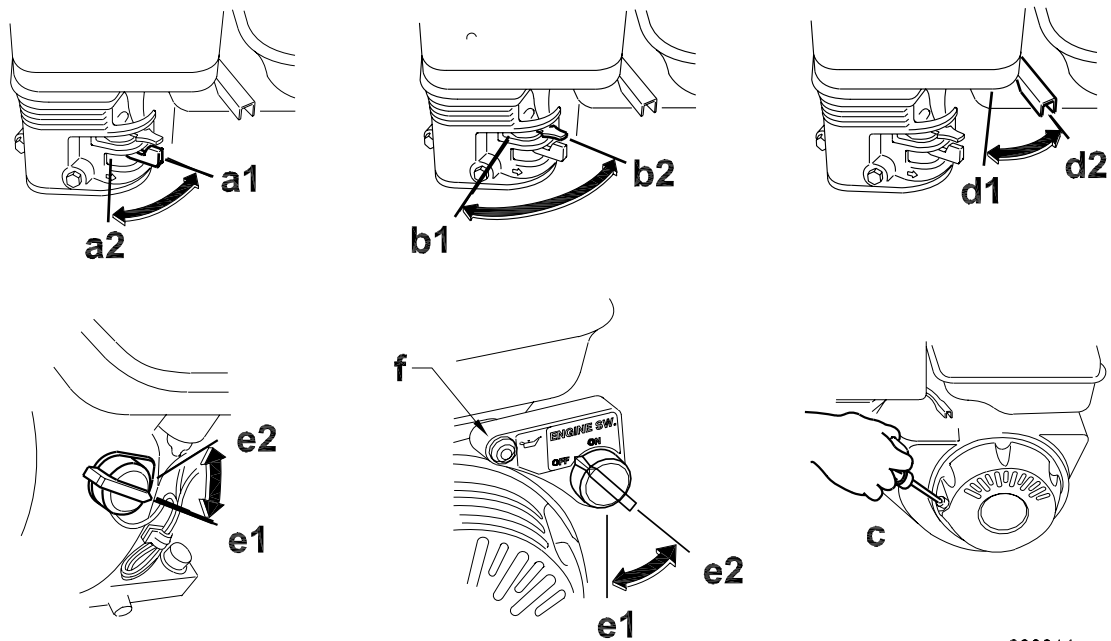

wc\_gr000014

## 4.8 To Stop (Honda)

See Graphic: wc\_gr000014

4.8.1 Reduce engine RPM to idle by moving throttle completely to right (**d2**).

4.8.2 Turn engine switch to "OFF" (**e2**).

4.8.3 Close fuel valve by moving lever to the left (**a2**).

### 4.9 To Start (Vanguard)

See Graphic: wc\_gr000015

4.9.1 Open fuel valve (a1).

**Note:** If engine is cold, move choke lever to the “CHOKE” position (b1).  
If engine is hot, set choke to the “RUN” position (b2).

4.9.2 Move throttle control to the fast position (c1).

4.9.3 Press stop switch to the on position (d1).

4.9.4 Pull starter rope (e).

**Note:** The engine is equipped with a low oil protection system. If the oil level is low, the engine will not start and the stop switch will flicker while the starter rope is pulled. If this happens, add oil to the engine.

4.9.5 Open choke to “RUN” position as engine warms (b2).

4.9.6 Open the throttle fully (c1) to operate the machine.

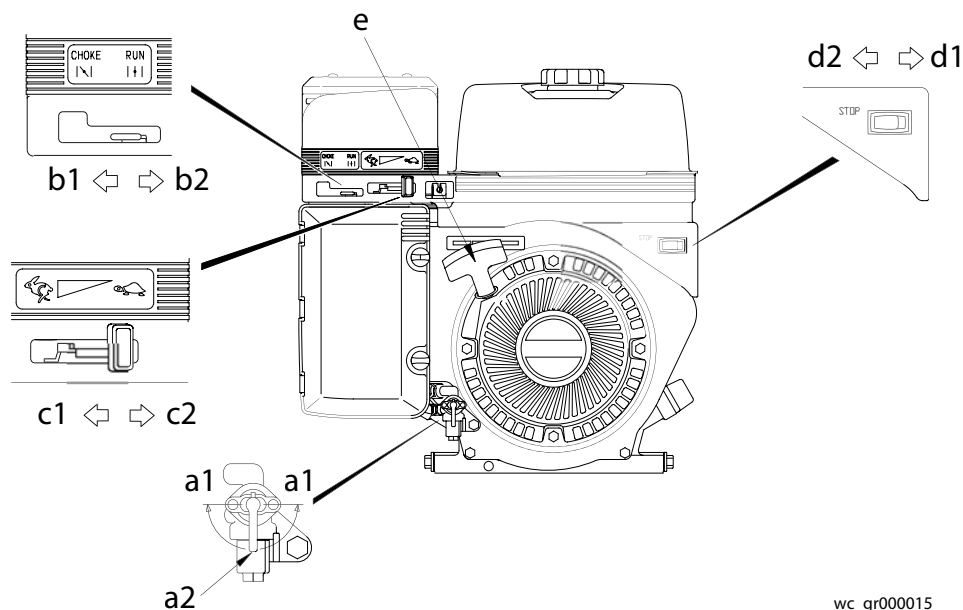

wc\_gr000015

### 4.10 To Stop (Vanguard)

See Graphic: wc\_gr000015

4.10.1 Reduce engine RPM by moving throttle completely to the idle position (c2).

4.10.2 Press engine switch to STOP (d2).

4.10.3 Close fuel valve (a2).

## 4.11 To Start (Hatz)

See Graphic: wc\_gr000016

- 4.11.1 Set speed control lever **(a)** either to 1/2 START or max. START position, as desired or necessary.

**Note:** Starting at a lower speed will help to prevent exhaust smoke.

- 4.11.2 Pull the starting cable out by hand until you feel a slight resistance **(b)**.

- 4.11.3 Let the cable run back; in this way the entire length of the starting cable can be used to start the engine.

- 4.11.4 Grip the handle with both hands.

- 4.11.5 Commence pulling the starting cable vigorously and at an increasing speed (do not jerk it violently) until the engine starts.

**Note:** If after several attempts of starting, the exhaust begins to emit white smoke, move the speed control lever to the STOP position and pull the starting cable out slowly 5 times. Repeat the starting procedure.

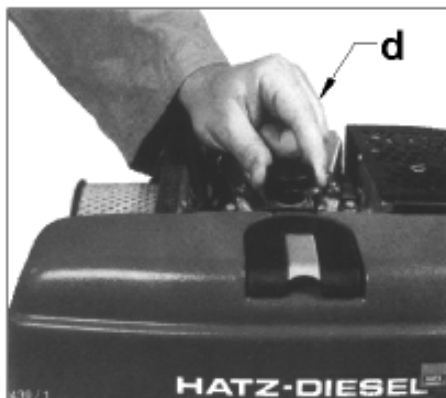
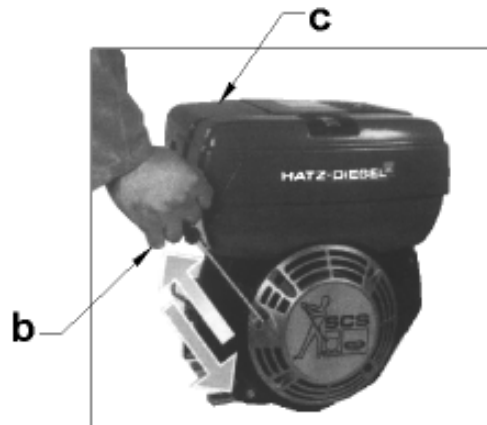
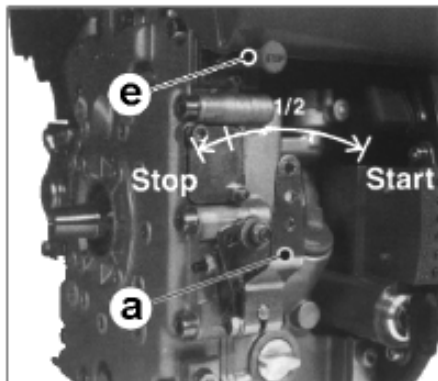

wc\_gr000016

## 4.12 Cold Weather Starting (Hatz)

See Graphic: wc\_gr000016

- 4.12.1 Set speed control lever **(a)** either to 1/2 START or max. START position, as desired or necessary.
- 4.12.2 Remove the top of the air cleaner and the soundproofing enclosure **(c)**.
- 4.12.3 Pull the oil feed knob up to its limit **(d)** and then push it back down to its seat.

**Note:** This ensures that the correct amount of oil will be fed to the engine when starting. The oil feed device automatically refills when the engine is running.

**NOTICE:** The oil feed device should only be used once per starting attempt.

- 4.12.4 Re-attach parts previously removed to the engine, then start it immediately.

## 4.13 To Stop (Hatz)

See Graphic: wc\_gr000016

- 4.13.1 Move engine speed control lever **(a)** to the STOP position.
- 4.13.2 Press in the STOP pin **(e)** for as long as it takes to stop the engine.

## 4.14 Operation

Pump should begin pumping water within a minute depending on length of suction hose and height of pump above water. Longer hoses will require more time.

If pump does not prime, check for loose fittings or air leak in suction hose. Make sure strainer in water is not blocked.

Run engine at full speed while operating pump.



Do not pump corrosive chemicals or water containing toxic substances. These fluids could create serious health and environmental hazards. Contact local authorities for assistance.

## 4.15 Hoses and Clamps

See Graphic: *wc\_gr000021*

Suction hoses **(a)** must be rigid enough not to collapse when pump is operating.

Discharge hoses **(b)** are usually thin-walled collapsible hoses. Rigid hoses similar to those used as suction hoses may also be used as discharge hoses.

**Note:** *Suction and discharge hoses are available from Wacker Neuson. Contact your nearest dealer for more information.*

Two clamps **(c)** are recommended for connection of suction hoses to inlet coupling.

**Note:** *This connection is important. Even a small air leak on the suction side of pump will prevent the pump from priming.*

For other hose connections, one T-bolt or worm-gear-type clamp is usually sufficient to hold hoses in place. In some cases, slight variances in hose diameters may make it necessary to add more clamps in order to maintain tight connections.

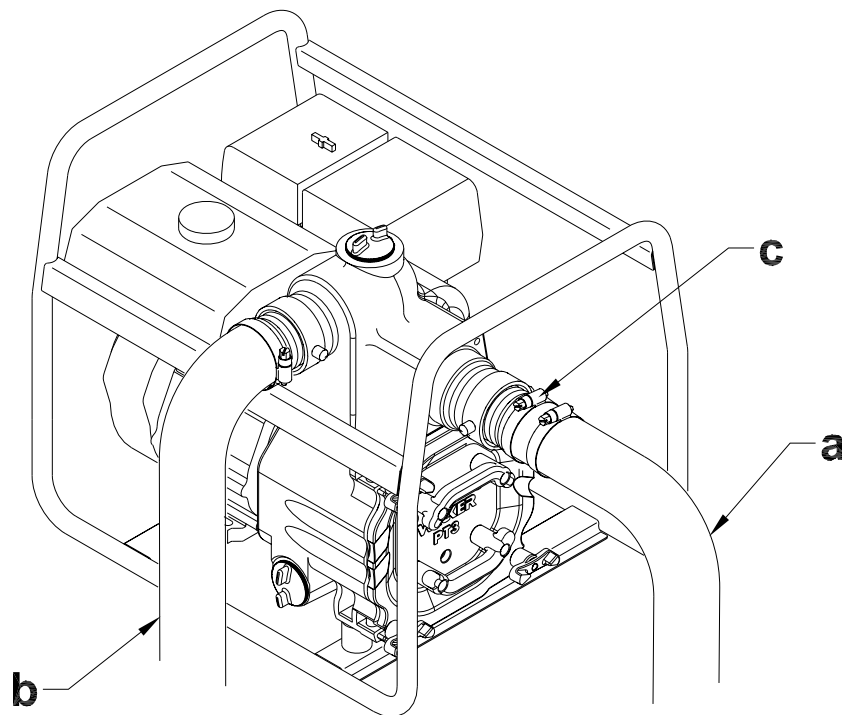

wc\_gr000021

## **4.16 Emergency Shutdown Procedure**

If a breakdown/accident occurs while the machine is operating, follow the procedure below.

- 4.16.1 Stop the engine.
- 4.16.2 Turn off the fuel supply.
- 4.16.3 Remove any obstructions.
- 4.16.4 Unkink the hoses.
- 4.16.5 Allow the machine to cool.
- 4.16.6 Contact the rental yard or machine owner.

## 5 Maintenance

### 5.1 Periodic Maintenance Schedule

The chart below lists basic machine and engine maintenance. Refer to your engine operator's manual for additional information on engine maintenance.

<b>Pump</b>	<b>Daily before starting</b>	<b>After first 20 hrs.</b>	<b>Every 50 hrs.</b>	<b>Every 100 hrs.</b>	<b>Every 300 hrs.</b>
Check external hardware.	■				
Inspect for leaks between pump and engine.	■				
Remove cover and clean sediment out of pump housing.	■				
Check housing cover O-rings.	■				
Inspect shockmounts for damage.	■				

<b>Wacker Neuson / Honda / Vanguard</b>	<b>Daily before starting</b>	<b>After first 20 hrs.</b>	<b>Every 50 hrs.</b>	<b>Every 100 hrs.</b>
Check fuel level.	■			
Check engine oil level.	■			
Inspect air filter. Replace as needed.	■			
Change engine oil.		■		■
Clean air cleaner.			■	
Clean sediment cup.				■
Check and clean spark plug.				■

Hatz	Daily before starting	After first 20 hrs.	Every 50 hrs.	Every 250 hrs.	Every 500 hrs.
Change engine oil and filter.		■		•	
Clean cooling air system.			■		
Check and adjust valve clearances.				■	
Clean or replace air filter.					■
Replace fuel filter.					■

## 5.2 Engine Oil System (Hatz)

See Graphic: wc\_gr000023, wc\_gr002682

### Engine Oil Level

- 5.2.1 Check the oil with the machine standing on a level surface.
- 5.2.2 Clean around the dipstick.
- 5.2.3 Check the oil level on the extended dipstick **(a)**. If necessary, top up to the “max” mark.



Engine may be hot enough to cause burns! Allow engine to cool prior to servicing.

### Changing Engine Oil

- 5.2.4 Change the oil with the machine standing on a level surface.
- 5.2.5 Run the engine for a few minutes and then stop the engine.
- 5.2.6 Drain the engine oil when it is still warm.

**Note:** *In the interests of environmental protection, place a plastic sheet and a container under the machine to collect any liquid which drains off. Dispose of this liquid in accordance with environmental protection legislation.*



Burn hazard. Care must be taken when draining hot engine oil. Hot oil can burn.

- 5.2.7 Unscrew the oil drain plug **(b)** and allow all the oil to drain into a container.



- 5.2.8 Clean the oil drain plug and attach a new seal **(c)**. Insert and tighten the plug.
- 5.2.9 Release filter screw **(d)** by hand and pull the oil filter out of its housing.
- 5.2.10 Use an air line to blow out oil filter dirt from the inside outwards.
- 5.2.11 Lightly oil the gaskets **(c)**.
- 5.2.12 Refit the oil filter. Apply slight pressure towards the engine block and tighten by hand.
- 5.2.13 Add engine oil.
- 5.2.14 Run for a short interval, then check at drain plug **(b)** for any leaks. Tighten if necessary.

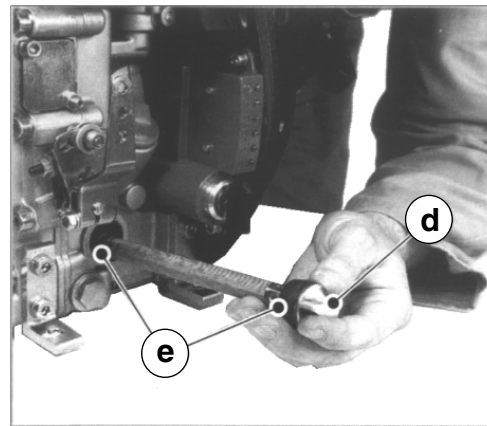
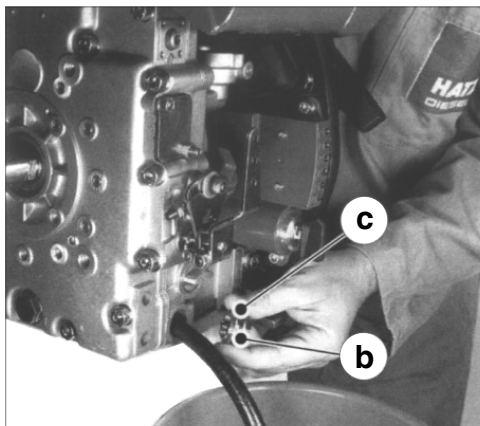
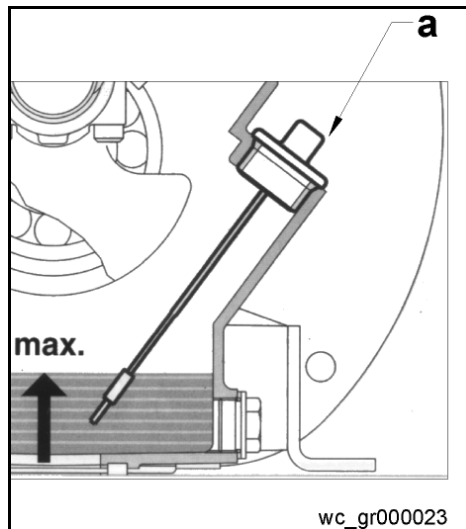

wc\_gr002682

### 5.3 Engine Oil (Wacker Neuson / Honda / Vanguard)

See Graphic: *wc\_gr000022*

5.3.1 Drain the oil while the engine is still warm.

5.3.2 Remove the oil filler plug **(a)** and the drain plug **(b)** to drain the oil.

**Note:** *In the interests of environmental protection, place a plastic sheet and a container under the machine to collect any liquid that drains off. Dispose of this liquid in accordance with environmental protection legislation.*

5.3.3 Install the drain plug.

5.3.4 Fill the engine crankcase with the recommended oil up to the level of the plug opening **(c)**. See section *Technical Data* for oil quantity and type.

5.3.5 Install the oil filler plug.

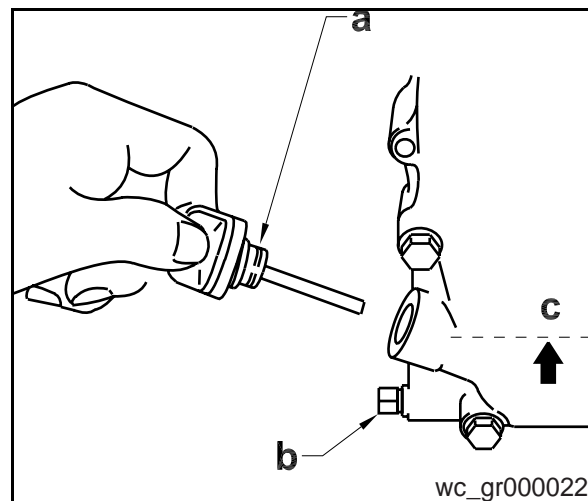

## 5.4 Air Cleaner (Wacker Neuson)

See Graphic: wc\_gr000656



**WARNING**

NEVER use gasoline or other types of low-flash point solvents for cleaning the air cleaner. A fire or explosion could result.

**NOTICE:** NEVER run the engine without the air cleaner. Severe engine damage will occur.

The engine is equipped with a dual-element air cleaner. Under normal operating conditions, the elements should be cleaned once every week. Under severe, dry and dusty conditions, the elements should be maintained daily. Replace an element when it is saturated with dirt that cannot be removed.

- 5.4.1 Remove the air cleaner cover (**a**). Remove the filter assembly by pulling it straight up. Inspect both elements for holes or tears. Replace damaged elements.
- 5.4.2 Wash the foam element (**b**) in a solution of mild detergent and warm water. Rinse it thoroughly in clean water. Allow the element to dry thoroughly.
- 5.4.3 Tap the paper element (**c**) lightly to remove excess dirt or blow compressed air through the filter from the inside out. Replace the paper element if it appears heavily soiled.

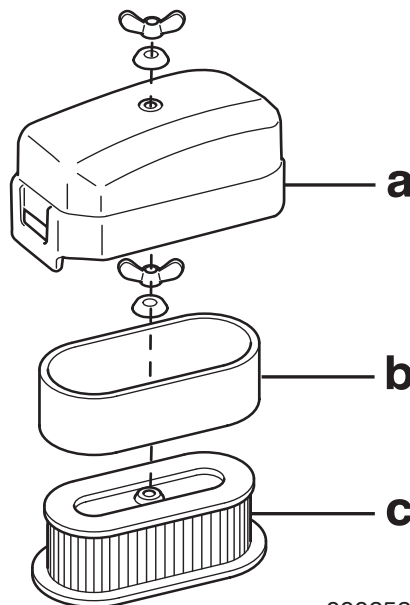

## 5.5 Air Cleaner (Honda)

See Graphic: wc\_gr000025

The engine is equipped with a dual element air cleaner. Service air cleaner frequently to prevent carburetor malfunction.

**NOTICE: NEVER** run engine without air cleaner. Severe engine damage will occur.



**WARNING**

**NEVER** use gasoline or other types of low flash point solvents for cleaning the air cleaner. A fire or explosion could result.

To service:

- 5.5.1 Remove air cleaner cover **(a)**. Remove both elements and inspect them for holes or tears. Replace damaged elements.
- 5.5.2 Wash foam element **(b)** in solution of mild detergent and warm water. Rinse thoroughly in clean water. Allow element to dry thoroughly. Soak element in clean engine oil and squeeze out excess oil.
- 5.5.3 Tap paper element **(c)** lightly to remove excess dirt. Replace paper element if it appears heavily soiled.

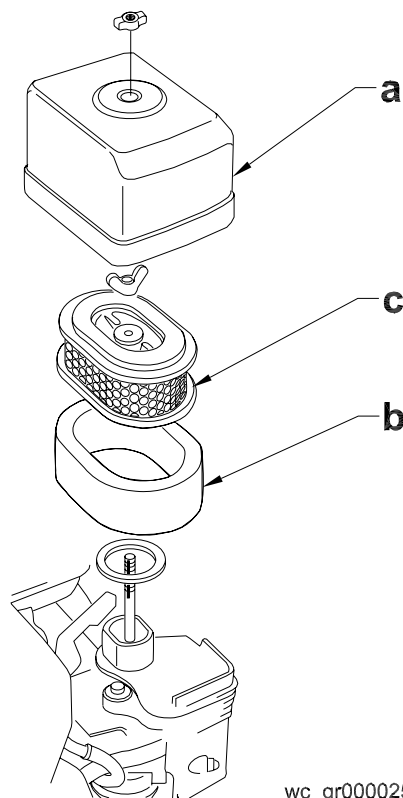

wc\_gr000025

## 5.6 Air Cleaner (Vanguard)

See Graphic: wc\_gr000026

Service air cleaner frequently to prevent carburetor malfunction.

**NOTICE:** NEVER run engine without air cleaner. Severe engine damage will occur.



NEVER use gasoline or other types of low flash point solvents for cleaning the air cleaner. A fire or explosion could result.

The engine is equipped with a dual element air cleaner. To service air cleaner:

- 5.6.1 Loosen cover knobs and remove cover **(a)** from air cleaner assembly. Remove both elements and retainer **(b)**. Inspect elements for holes or tears. Replace damaged elements.  
Foam element (pre-cleaner) **(c)**:
- 5.6.2 Wash in solution of mild detergent and warm water.
- 5.6.3 Rinse thoroughly in clean water. Allow element to dry thoroughly.
- 5.6.4 Soak element in clean engine oil and squeeze out excess oil.  
Paper element **(d)**:
- 5.6.5 Tap element lightly to remove excess dirt. Replace paper element if it appears heavily soiled. Do not oil paper element.

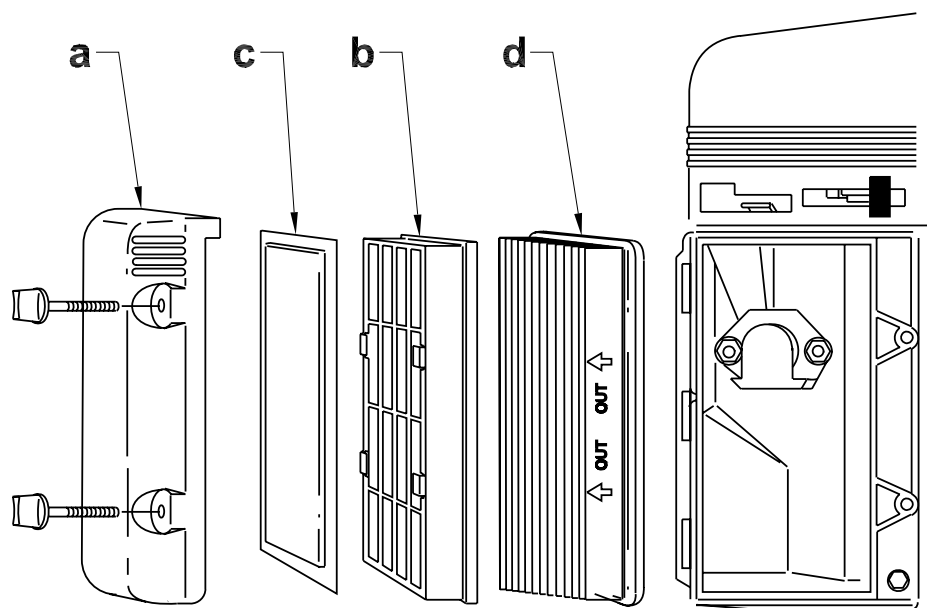

wc\_gr000026

## 5.7 Air Cleaner (Hatz)

See Graphic: *wc\_gr000027*

The filter cartridge should always be replaced after 500 operating hours at the latest.

5.7.1 Remove the air cleaner cover (**a**).

5.7.2 Unscrew and remove knurled nut (**b**) and take off air cleaner element (**c**).

5.7.3 Clean the filter compartment and the cover. Dirt and other foreign debris must not be allowed to enter the engine's air inlet points.

The filter cartridge should either be replaced or, depending upon the degree of contamination, cleaned or checked, as follows:

### Dry Contamination:

- Use compressed air to blow through the filter cartridge from the inside outwards, until no further dirt emerges.

**NOTICE:** The air pressure must not exceed 73 psi (5 bar).

### Moist or Oily Contamination:

- Replace the filter cartridge.

### Checking the Filter Cartridge:

- Check filter cartridge's gasket surface (**d**) for damage.
- Check the filter cartridge for cracks or any other type of damage to the paper filter by holding it inclined towards the light or by shining a light source through it.

**NOTICE:** If there is the slightest damage to the paper filter, do not re-use.

- Re-assemble the filter cartridge in reverse order.

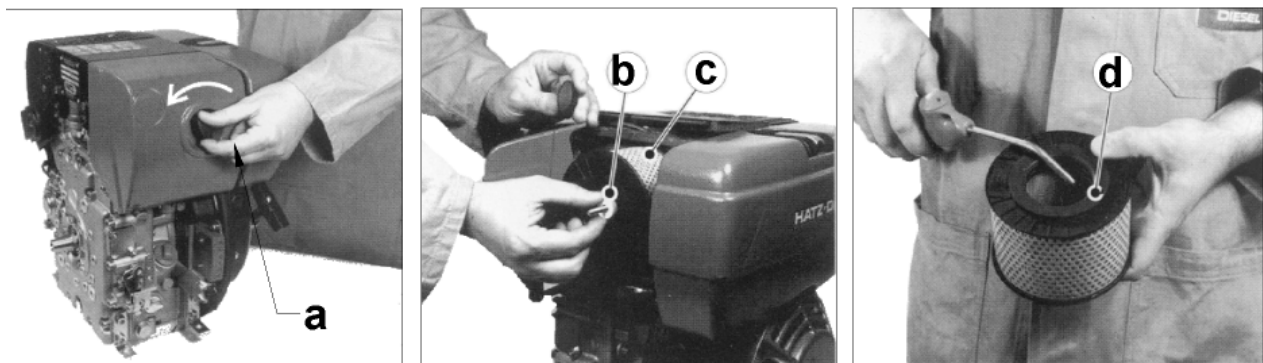

*wc\_gr000027*

## 5.8 Spark Plug (Wacker Neuson / Honda / Vanguard)

See Graphic: *wc\_gr000028*

Clean or replace the spark plug as needed to ensure proper operation. Refer to your engine operator's manual.



**WARNING**

The muffler becomes very hot during operation and remains hot for a while after stopping the engine. Do not touch the muffler while it is hot.

**Note:** Refer to section "Technical Data" for the recommended spark plug type and the electrode gap setting.

- 5.8.1 Remove the spark plug and inspect it.
- 5.8.2 Replace the spark plug if the insulator is cracked or chipped.
- 5.8.3 Clean the spark plug electrodes with a wire brush.
- 5.8.4 Set the electrode gap **(a)**.
- 5.8.5 Tighten the spark plug securely.

**NOTICE:** A loose spark plug can become very hot and may cause engine damage.

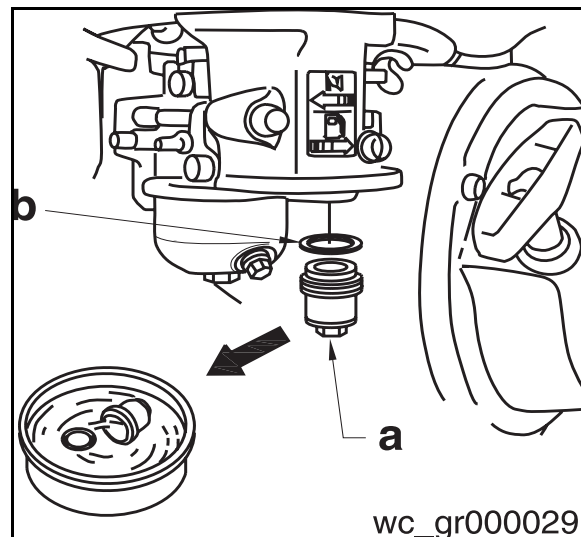
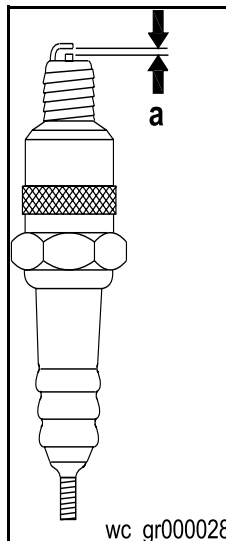

## 5.9 Sediment Cup (Honda)

See Graphic: *wc\_gr000029*

- 5.9.1 Turn the fuel valve off.
- 5.9.2 Remove the sediment cup **(a)** and the O-ring **(b)**.
- 5.9.3 Wash both thoroughly in a nonflammable solvent. Dry and reinstall them.
- 5.9.4 Turn the fuel valve on and check for leaks.

## 5.10 Cleaning Fuel Strainer (Wacker Neuson)

See Graphic: *wc\_gr001093*

- 5.10.1 To remove water and dirt, close the fuel lever and remove the fuel strainer.
- 5.10.2 Inspect the fuel strainer **(a)** for water and dirt.
- 5.10.3 After removing any dirt and water, wash the fuel cup with a nonflammable solvent.
- 5.10.4 Reinstall securely to prevent leakage.

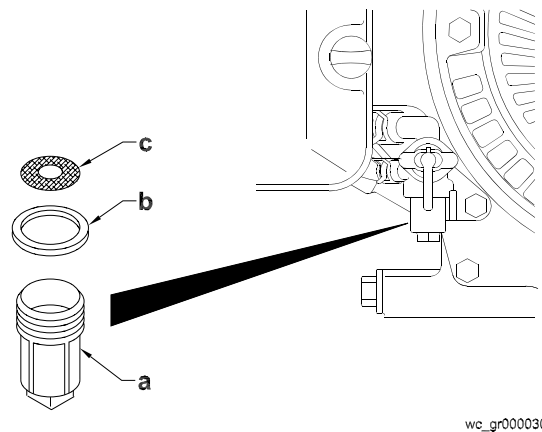
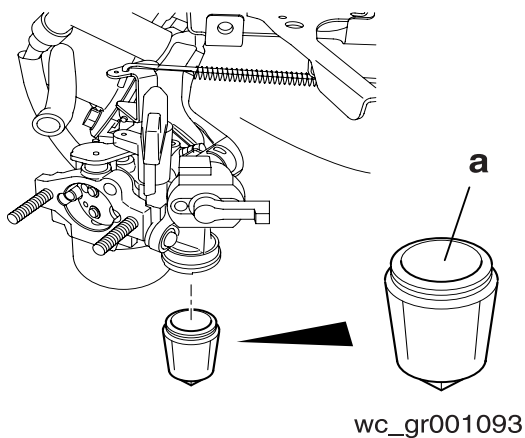

## 5.11 Fuel Filter (Vanguard)

See Graphic: *wc\_gr000030*

- 5.11.1 Turn fuel valve off.
- 5.11.2 Remove bowl **(a)** gasket **(b)** and screen **(c)**.
- 5.11.3 Wash them thoroughly in a nonflammable solvent. Dry them and reinstall.
- 5.11.4 Turn fuel valve on and check for leaks.



## 5.12 Fuel Filter (Hatz)

See Graphic: wc\_gr000031

Fuel filter maintenance intervals depend on the purity of the diesel fuel used. If your fuel is dirty, perform this operation at 250 hours.



**WARNING**

Danger of explosion. Diesel fuel is flammable and must be treated with the necessary caution. Do not smoke. Avoid sparks and open flames.

- 5.12.1 Remove the fuel tank cap **(a)** and drain fuel tank.
- 5.12.2 Unscrew fuel line **(b)** at filter **(c)** and insert a new filter.
- 5.12.3 Fit the fuel filter again and close the tank cap.

**Note:** Bleeding of the fuel injection system takes place automatically.

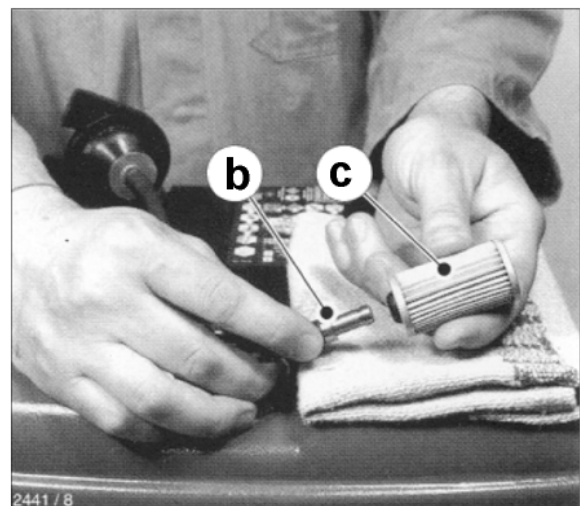

wc\_gr000031

### 5.13 Carburetor (Wacker Neuson / Honda)

See Graphic: *wc\_gr000032*

- 5.13.1 Start the engine and allow it to warm up to operating temperature.
- 5.13.2 Set the pilot screw **(a)** two turns out. See *Note*.
- 5.13.3 With the engine idling, turn the pilot screw **(a)** in or out to the setting that produces the highest rpm.
- 5.13.4 After the pilot screw is adjusted, turn the throttle stop screw **(b)** to obtain the standard idle speed. See *Technical Data*.

**Note:** *On some engines the pilot screw is fitted with a limiter cap (c) to prevent excessive enrichment of the air-fuel mixture in order to comply with emission regulations. The mixture is set at the factory and no adjustment should be necessary. Do not attempt to remove the limiter cap. The limiter cap cannot be removed without breaking the pilot screw.*

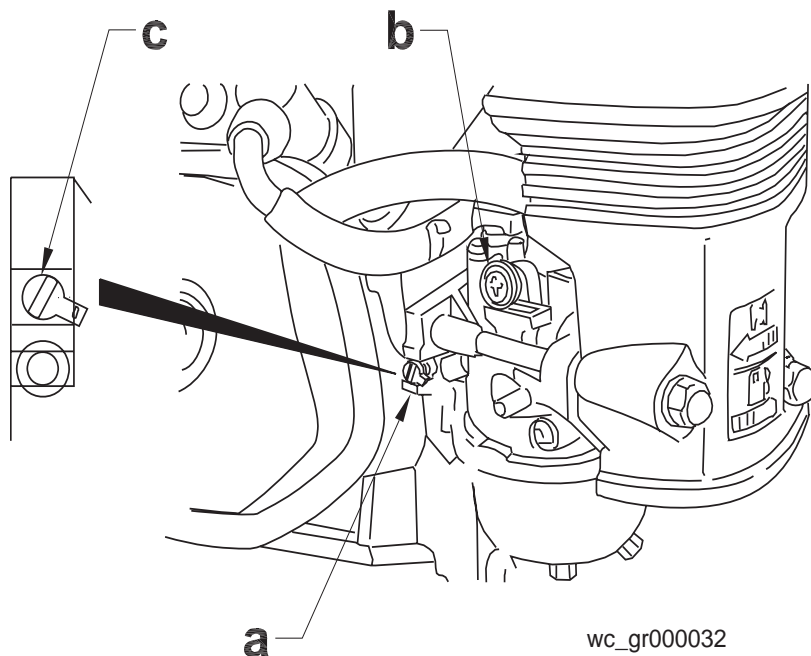

## 5.14 Carburetor (Vanguard)

See Graphic: *wc\_gr000033*

- 5.14.1 Start engine and allow it to warm up to operating temperature.
- 5.14.2 Place throttle control in idle position. Hold carburetor throttle lever (**a**) against idle speed screw (**b**) to obtain 1300 RPM.
- 5.14.3 While still holding carburetor throttle lever against idle speed screw, turn idle mixture screw (**c**) clockwise (lean) or counterclockwise (rich) until engine runs smoothly. Release carburetor throttle lever.
- 5.14.4 Adjust governed idle screw (**d**) to 1400 RPM. Move throttle control to the fast position. Engine should accelerate smoothly. If it does not, readjust carburetor, usually to a slightly richer mixture, by turning idle mixture screw (**c**) 1/8 turn counterclockwise.
- 5.14.5 Adjust top speed screw (**f**) to 3500 RPM.

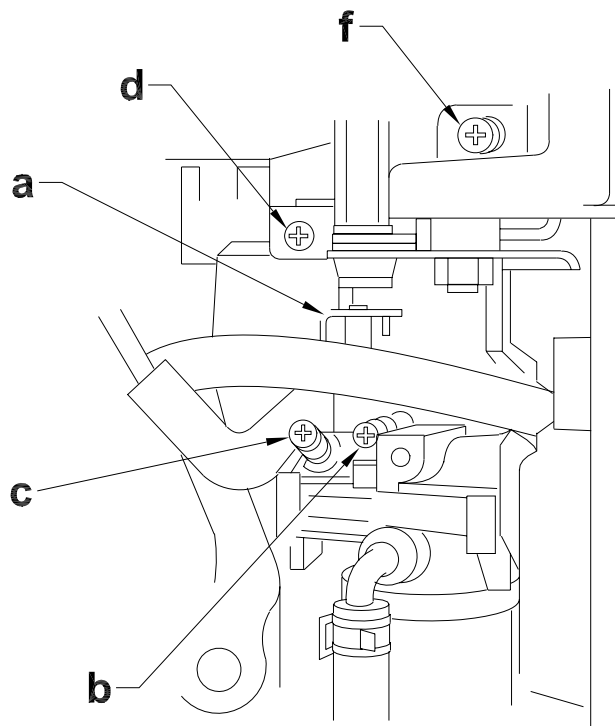

wc\_gr000033

## 5.15 Valve Clearances (Hatz)

See Graphic: *wc\_gr000034*

Only carry out adjustments when the engine is cold (42–62°F / 10–30°C).

- 5.15.1 Remove air cleaner cover and noise-insulating hood.
- 5.15.2 Remove any contamination adhering to the cover for the cylinder head.
- 5.15.3 Pull oil feed knob as far as the limit stop.
- 5.15.4 Remove screws **(a)** and take off the cylinder head cover with gasket **(b)**.
- 5.15.5 Remove rubber cap from the inspection hole cover **(c)**.
- 5.15.6 Turn the engine over in the normal direction of rotation until the valves are in the overlap position (exhaust valve not yet closed, inlet valve starts to open).
- 5.15.7 Turn crankshaft through 360° in direction of rotation and position it precisely at the TDC mark **(d)**.
- 5.15.8 Check valve clearance with feeler gauge **(e)**.  
**Note:** *Refer to the Technical Data for valve clearances.*
- 5.15.9 If valve clearances require adjusting, slacken off screw **(f)** and turn hex nut **(g)** until feeler gauge can be pulled through with just slight resistance when screw is retightened.
- 5.15.10 Check the O-rings **(h)** on the oil feed for cracks and/or damage.
- 5.15.11 Fit cover for cylinder head and tighten evenly, always using a new gasket.
- 5.15.12 Re-attach parts previously removed from engine.  
**Note:** *Don't forget to replace the rubber cap at the inspection hole cover.*
- 5.15.13 Carry out a brief test run, then check the cover for leaks.

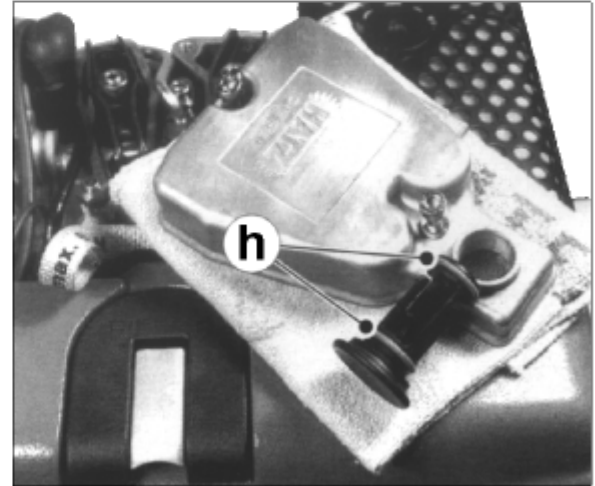
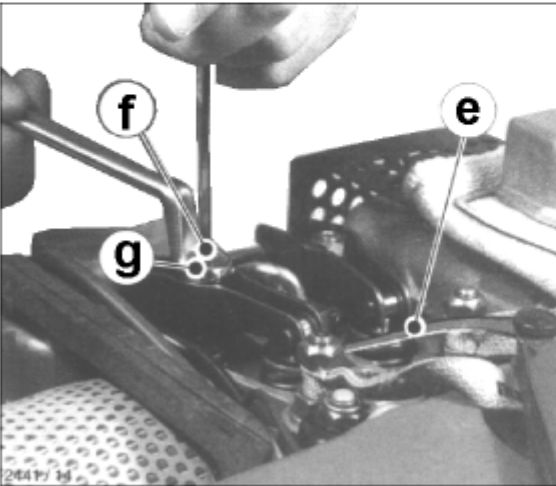
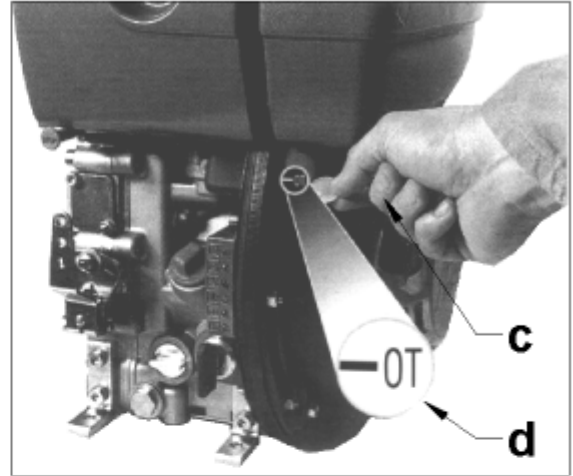
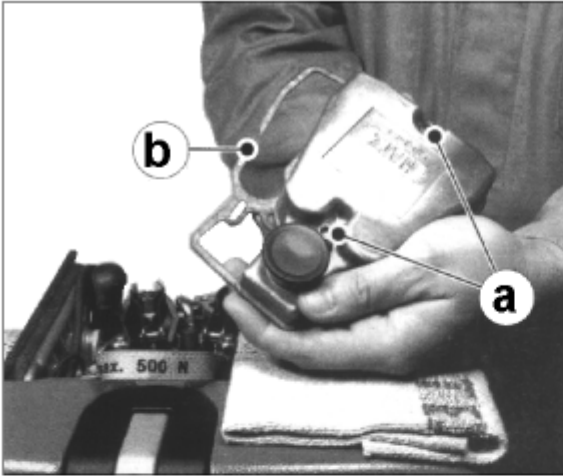

wc\_gr000034

## 5.16 Adjusting Impeller Clearance

See Graphic: *wc\_gr000035*

If it is necessary to replace the impeller or the volute insert, be sure clearance between impeller and insert is adjusted correctly. The impeller **(a)** should be as close to the insert **(b)** as possible without rubbing against it. Clearance is adjusted by adding or removing shims **(c)**.

5.16.1 Remove spark plug (on units with Hatz engine, place speed control lever in STOP position) so that engine will not start.

5.16.2 Check clearance between impeller and insert by slowly pulling starter rope to turn impeller.

If starter rope is difficult to pull, or rubbing is heard from inside pump, the impeller and insert are too close to each other. Remove a shim from behind insert and check again for rubbing. Continue removing shims until impeller turns easily.

**Note:** *It is important not to remove too many shims or the clearance between the impeller and insert will become too wide and pump performance will be reduced.*

As the impeller wears down, additional shims may be required to maintain the clearance between the impeller and insert.

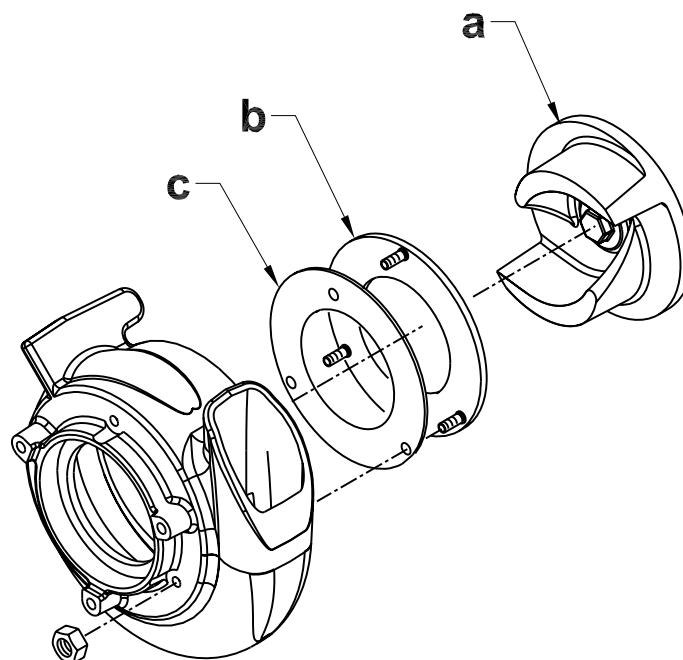

*wc\_gr000035*

## 5.17 Cleaning Pump

See Graphic: *wc\_gr000036*

Clean inside of pump housing after every use.

- 5.17.1 Remove drain plug **(a)** from pump housing and drain any water left in pump.
- 5.17.2 Loosen the four knobs holding the pump cover **(b)** and remove cover.
- 5.17.3 Clean out dirt and debris. Inspect impeller and volute insert for wear.



The impeller may develop sharp edges. Use care when cleaning around impeller to avoid getting cut.

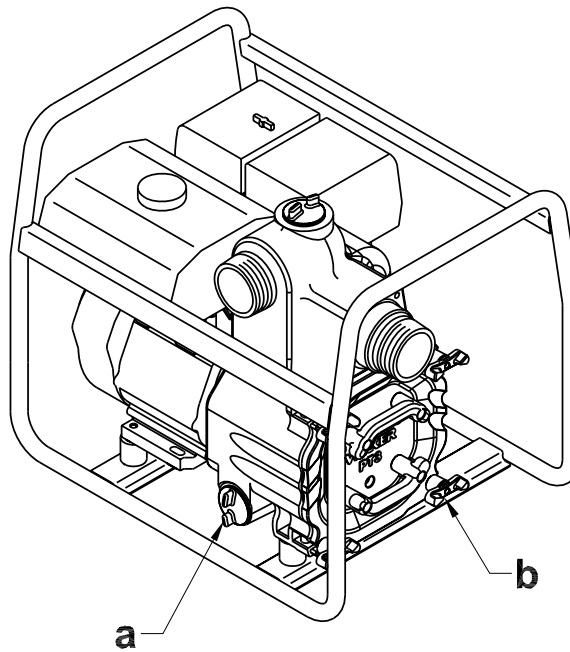

*wc\_gr000036*

## 5.18 Storage

If pump is being stored for more than 30 days:



**WARNING**

Do not open priming plug, discharge plug, or cover when pump is hot.

- 5.18.1 After pump has cooled, remove discharge plug from pump housing and drain out any water left in the housing.
- 5.18.2 Remove pump cover and clean inside of pump housing. Coat inside of pump with a light film of oil to reduce corrosion. A spray can of oil works well for this.
- 5.18.3 Tape up suction and discharge ports to prevent anything from falling into pump.
- 5.18.4 Change engine oil and follow procedures described in engine manual for engine storage.
- 5.18.5 Cover pump and engine and store in a clean, dry area.

## 5.19 Accessories

Wacker Neuson offers a complete line of fittings, hoses, and clamps to properly connect the pump to match various job conditions.



## 5.20 Troubleshooting

Problem / Symptom	Reason / Remedy
Pump does not take in water.	<ul style="list-style-type: none"> <li>• Not enough priming water in housing.</li> <li>• Engine speed too low. Adjust speed.</li> <li>• Strainer plugged. Clean strainer.</li> <li>• Suction hose damaged. Replace or repair hose.</li> <li>• Air leak at suction port. Check that fittings are tight and housing cover O-rings are sealing properly.</li> <li>• Pump too high above water.</li> <li>• Debris collecting in pump housing. Clean pump housing.</li> <li>• Too much clearance between impeller and insert.</li> </ul>
Pump takes in water, little or no discharge.	<ul style="list-style-type: none"> <li>• Engine speed too low. Adjust speed.</li> <li>• Suction strainer partially plugged. Clean strainer.</li> <li>• Impeller worn. Adjust clearance by adding shims or replace impeller.</li> <li>• Volute insert worn or damaged. Adjust clearance or replace insert.</li> </ul>
Suction hose leaks at inlet.	<ul style="list-style-type: none"> <li>• Clamps are not sealing properly. Tighten, replace, or add clamp.</li> <li>• Hose diameter is too large.</li> <li>• Hose is damaged.</li> </ul>
Discharge hose does not stay on coupling.	<ul style="list-style-type: none"> <li>• Pressure may be too high for clamps being used. Add another clamp.</li> <li>• Hose kinked or end blocked. Check hose.</li> </ul>
Impeller does not turn; pump is hard to start.	<ul style="list-style-type: none"> <li>• Impeller jammed or blocked. Open pump cover and clean dirt and debris from inside of pump housing.</li> <li>• Impeller and insert binding. Adjust clearance by removing shim from behind insert.</li> </ul>

**6. Technical Data**

**6.1 Engine**

**Engine Power Rating**

Net power rating per SAE J1349 and ISO 3046. Actual power output may vary due to conditions of specific use.

Item No.		PT 2	PT 2A	PT 2V	PT 2H
<b>Engine</b>					
Engine Type		4-stroke, overhead valve, single cylinder		4-stroke, single cylinder, air cooled	4-stroke, air cooled, diesel engine
Engine Make		Wacker Neuson	Honda	Briggs & Stratton	Hatz
Engine Model		WM170	GX 160 K1 TX2	Vanguard 117432-0235-E2	1B 20
Max. rated power at rated speed	kW (Hp)	4.2 (5.7) @ 4000 rpm	3.6 (4.8) @ 3600 rpm	4.5 (6) @ 3600 rpm	3.4 (4.6) @ 3600 rpm
Displacement	cm <sup>3</sup> (in <sup>3</sup> )	169 (10,3)	163 (9.4)	182 (11.1)	232 (14.2)
Spark Plug		(NGK) BR 6HS Champion RL86C	(NGK) BPR 6ES BOSCH WR7DC	Champion	—
Electrode Gap	mm (in)	0.6–0.7 (0.024–0.028)	0.7-0.8 (0.028–0.031)		—
Operating speed	rpm	3500			
Engine Speed - idle	rpm	1600 ±100			
Valve Clearance (cold)					
intake:	mm (in.)	—	—	—	0.10 (0.004)
exhaust:					0.20–0.25 (0.008–0.01)
Air Cleaner	type	Dual Element			Dry Pleated Paper Element
Engine Lubrication	oil grade	SAE 10W30 Service Class SF, SE, SD, or SC			CD, CE, CF, CG Rated
Engine Oil Capacity	l (oz.)	0.6 (20)		0.7 (24)	0.9 (34)
Fuel	type	Regular Unleaded Gasoline			No. 2 Diesel
Fuel Tank Capacity	l (qts.)	3.6 (3.8)	3.6 (3.8)	4.0 (4.2)	3.0 (3.2)

## 6.2 Pump

Item No.		PT 2(I)	PT 2	PT 2A	PT 2V	PT 2H
<b>Pump</b>						
Dimensions	mm (in.)	550 x 465 x 500 (21.7 x 18.3 x 19.6)			590 x 495 x 510 (23.2 x 19.4 x 20)	
Weight	kg (lbs.)	—	43 (96)		49 (107)	59 (131)
*Max. Suction Lift	m (ft.)	*7.5 (25)				
Max. Total Head	m (ft.)	32 (106)				
Max. Pressure	bar (psi)	3,2 (46)				
Max. Flow Rate	m <sup>3</sup> /hr (gpm)	48 (210)				
Suction / Discharge Dia.	mm (in.)	50 (2)				
Max. Solid Size	mm (in.)	25 (1)				

\*Based on pump operating at sea level. Maximum suction lift will be less at higher altitudes.

## 6.3 Sound Measurements

The required sound specification, Paragraph 1.7.4.f of 89/392/EEC Machinery Directive, is:

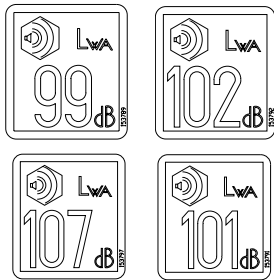

Guaranteed sound power level ( $L_{WA}$ ) = **PT 2A** 102 dB(A), **PT 2V** 99 dB(A), **PT 2H** 107 dB(A), **PT 2** 101 dB(A).

The sound pressure level at operator's location ( $L_{pA}$ ) = **PT 2A** 91 dB(A), **PT 2V** 88 dB(A), **PT 2H** 99 dB(A), **PT 2** 89 dB(A).

These sound values were determined according to ISO 3744 for the sound power level ( $L_{WA}$ ) and ISO 6081 for the sound pressure level ( $L_{pA}$ ) at the operator's location.



PORTABLE PUMPS

[www.aem.org](http://www.aem.org)



# SAFETY MANUAL

FOR OPERATING AND MAINTENANCE PERSONNEL

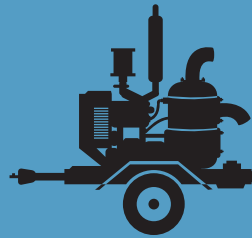
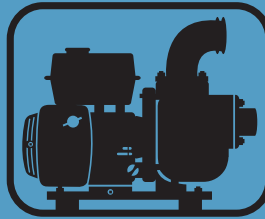

## SAFETY ALERT SYMBOL



This Safety Alert Symbol means  
**ATTENTION** is involved!

The Safety Alert Symbol identifies important safety messages on machines, safety signs, in manuals, or elsewhere. When you see this symbol, be alert to the possibility of personal injury or death. Follow the instructions in the safety message.

*Why is SAFETY important to YOU?*

### 3 BIG REASONS

- **Accidents KILL or DISABLE**
- **Accidents COST**
- **Accidents CAN BE AVOIDED**

## NOTICE OF COPYRIGHT PROTECTION

AEM Safety Manuals are protected as a copyrighted work with ownership duly registered with the Copyright Office, Washington, D.C. Any reproduction, translation, decompiling or other use of an AEM Safety Manual, or portion thereof, or the

creation of derivative works based on an AEM Safety Manual, without the prior written approval of AEM is expressly prohibited. Copyright infringement can result in civil and criminal sanctions, damages and other penalties being imposed.

Copyright © 2004— Association of Equipment Manufacturers

1

## REFERENCES

---

The following is a partial list of referenced material on safe operating practices:

U.S. Department of Labor publishes safety and health regulations and standards under the authority of the Occupational Safety and Health Act for the general construction and mining industries.

U.S. Department of Labor  
Washington, DC 20210

NFPA — National Fire Protection Association  
P.O. Box 9101  
1 Battery March Park  
Quincy, MA 02269-9101

SAE — Society of Automotive Engineers, Inc.  
400 Commonwealth Drive  
Warrendale, PA 15096  
Publishes a list, "Operator Precautions" SAE J153  
MAY 87.

AEM — Association of Equipment Manufacturers  
111 East Wisconsin Avenue  
Milwaukee, WI 53202

# CONTENTS

	Page	Section
FOREWORD.....	4	
FOLLOW A SAFETY PROGRAM .....	5	<b>1</b>
PERFORM MAINTENANCE SAFELY .....	7	<b>2</b>
PREPARE FOR SAFE OPERATION .....	9	<b>3</b>
WORK SAFELY – Pumps In General .....	10	<b>4</b>
WORK SAFELY – Engine Driven Pumps.....	13	<b>5</b>
WORK SAFELY – Electric Motor Driven Pumps.....	15	<b>6</b>
WORK SAFELY – Submersibles .....	17	<b>7</b>
TEST YOUR KNOWLEDGE .....	19	<b>8</b>
FINAL WORD TO THE USER .....	20	<b>9</b>

## FOREWORD

This safety manual is intended to point out some of the basic situations which may be encountered during the normal operation and maintenance of your equipment, and to suggest possible ways of dealing with these conditions.

Additional precautions may be necessary, depending on application, pump type, configuration and attachments used, conditions at the work-site or in the maintenance area. The manufacturer has no direct control over pump application, operation, inspection, lubrication or maintenance. Therefore, it is your responsibility to use good, safe, practices in these areas.

The information provided in this manual supplements the specific information about your pump that is contained in the manufacturer's manual(s). Other information which may affect the safe operation of your pump may be contained on safety signs, decals, markings, insurance requirements, employer's safety programs, safety codes, local, state/provincial and federal laws, rules and regulations, contracts, agreements and warranties.

It is your responsibility to read and understand this safety manual and the manufacturer's manual(s) before operating your pump. This safety manual takes you step-by-step through your working day. If you do not understand any of this information, or if errors or contradictions seem to exist, consult with your supervisor before operating your pump.

**IMPORTANT: If you do not have the manufacturer's manual(s) for your particular pump, get a replacement manual from your employer, equipment dealer, or manufacturer of your pump. Keep this safety manual and the manufacturer's manual(s) with your pump.**

Unauthorized modifications of pumps create hazards. Pumps must not be modified or altered unless prior approval is obtained from the manufacturer.

**DO NOT PUMP VOLATILE/FLAMMABLE OR CAUSTIC/CORROSIVE LIQUIDS.**

**REFER TO THE OWNER'S MANUAL OR CONSULT WITH THE MANUFACTURER FOR THE PROPER PUMP MATERIALS IF YOU ARE TO PUMP HAZARDOUS CAUSTIC/CORROSIVE LIQUIDS.**

# FOLLOW A SAFETY PROGRAM

## KNOW THE RULES

Every employer is concerned about safety. Safe operation and proper maintenance of your pump can prevent accidents. **KNOW** the rules — **LIVE** by them. (FIG. 1)

When starting work at a new site, check with the designated safety coordinator for specific safety instructions. **DON'T LEARN SAFETY THE HARD WAY.**

Know the meaning of all hand signals, signal flags, signs and markings.

Know the traffic rules used at the work site. Know who the signal man is; watch and obey his signals.

Know where the fire extinguishers and first aid kits are kept and how to use them. Know where to get proper aid and assistance when needed.

Use common sense to avoid accidents. If an accident does occur, be prepared to react to it quickly and effectively.

**NEVER PANIC.**

Remember that **YOU are the key to safety.** Good safety practices not only protect you but also protect the people around you. Study this manual and the manufacturer's manual(s) for your specific pump. Make them a working part of your safety program. Keep in mind that this safety manual is written for only this type of equipment. Practice all other usual and customary safe working precautions, and above all (FIG. 1).

**REMEMBER — SAFETY IS UP TO YOU**

**YOU CAN PREVENT  
SERIOUS INJURY OR DEATH**



FIG. 1

1

5

# FOLLOW A SAFETY PROGRAM

## KNOW WHAT IT IS?

Consult your supervisor for specific instructions and personal safety equipment required.

For instance, you may need:

- Hard Hat
- Safety Shoes
- Eye Protection
- Respirators
- Heavy Gloves
- Reflector Vests
- Hearing Protection
- Face Protection
- Back Supports
- Other job related specific items

Do not wear loose clothing or any accessory — flopping cuffs, untied shoe-laces, dangling neckties and scarves, rings, wrist watches, or other jewelry — that can catch on protruding or moving parts or controls. Long hair should be securely bound to prevent entanglement with moving parts. (FIG. 3)



FIG. 2



FIG. 3

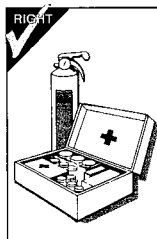

FIG. 4

## BE ALERT!

Know where to get assistance. Know how to use a first aid kit and fire extinguisher or fire suppression system. (FIG. 4)

## BE AWARE!

Take advantage of training programs offered.

Safety programs should require that one person at each jobsite be assigned the overall responsibility and authority for safety. Know who the person is, and **COMMUNICATE** with them.

Know what the jobsite rules are, and **FOLLOW THE RULES.** Be safety conscious, responsible and reliable. Think about safety **BEFORE** something happens.

## BE CAREFUL!

Human error is caused by many factors: carelessness, fatigue, overload, preoccupation, incompatibility between operator and the equipment, drugs, and alcohol to name a few. Damage to the equipment can be fixed in a short period of time, but injury, or death has a lasting effect.

For your safety and safety of others, encourage your fellow workers to act within safety rules.

1

6



## PERFORM MAINTENANCE SAFELY

### CLOTHING AND PERSONAL PROTECTIVE ITEMS

ALWAYS wear appropriate safety glasses, goggles or face shield when working. (FIG. 2) Proper eye protection can keep flying particles from grinding, drilling or hammering operations, or fluids such as fuel, solvents, lubricants and brake fluids from damaging your eyes. Normal glasses do NOT provide adequate protection.

ALWAYS wear a hard hat and safety shoes. (FIG. 2) ALWAYS wear hearing protectors when exposed to high noise levels for extended periods. ALWAYS wear a respirator when painting or exposed to dusty conditions. ALWAYS keep your pockets free of loose objects which can fall out and drop into machinery. (FIG. 5) Heavy gloves should be worn for many operations.

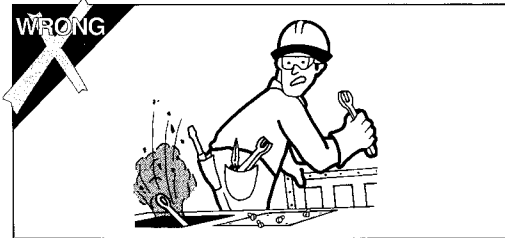

FIG. 5

### EXHAUST FUMES

Engine exhaust fumes can cause sickness or death. If it is necessary to run an engine in an enclosed area, remove the exhaust fumes from the area with an exhaust pipe extension. If you do not have an exhaust pipe extension, be positive the area is adequately ventilated. (FIG. 6)

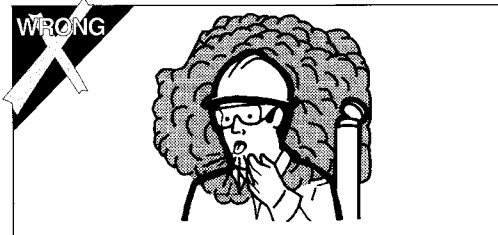

FIG. 6

### HEAVY PARTS

Handle tools and heavy parts sensibly — with regard for yourself and other persons. Lower items — don't throw or drop them.

ALWAYS use proper hoisting equipment for lifting heavy loads.

ALWAYS use a back brace when lifting by hand.

2

## PERFORM MAINTENANCE SAFELY

### FIRE PREVENTION

Whenever possible use a nonflammable solvent to clean parts. Do not use gasoline or other fluids that give off harmful vapors.

If flammable fluids, such as gasoline or diesel fuel, must be used, extinguish open flames or sparks and DO NOT smoke.

Store dangerous fluids in a suitable place, in approved containers which are clearly marked. NEVER smoke in areas where flammable fluids are used or stored. (FIG. 7)

Use proper nonflammable cleaning solvents. Follow solvent manufacturer's instructions for use.

Always remove all flammable material in the vicinity of welding and/or burning operations.

ALWAYS keep the floor in the work area clean and dry. Oily, greasy floors can easily lead to falls. Wet spots, especially near electrical equipment, can be hazardous. (FIG. 7)

Know where fire extinguishers are kept — how they operate — and for what type of fire they are intended.

Check readiness of any fire detectors and fire suppression systems.



FIG. 7

2

7

# PREPARE FOR SAFE OPERATION

## LEARN TO BE SAFE

NEVER operate a pump which is new to you without first being instructed in its proper operation. READ the operator's manual. If one has not been provided, GET ONE AND STUDY IT BEFORE OPERATING THE PUMP.

Know the meaning of all identification symbols on your controls and gauges. (FIG. 8)

Know the location of the emergency shut-down control if the machine is so equipped.

Before attempting to operate the pump, know the capabilities and limitations of the pump. Familiarize yourself with controls and instruments — their locations and functions.

Keep hands, levers and knobs clean of oil or grease to prevent slipping.

Carefully read and follow the instructions on all safety signs and decals on the pump. Keep safety signs in good condition. Replace missing or damaged safety signs.



FIG. 8

## CHECK IT OUT!

Know what safety devices your machine is equipped with ... and see that each item is securely in place and in operating condition. (FIG. 9)

For example:

- Drawbar Coupling Chains and Pins
- Alarms and Warning Lamps
- Reflectors
- Guards and Shields
- Drain Covers, Plugs, and Caps
- Shut-Down Devices
- Leveling Jacks
- Pressure Relief Devices
- Lifting Devices



FIG. 9

NEVER START OR OPERATE A PUMP KNOWN OR SUSPECTED TO BE DEFECTIVE OR MALFUNCTIONING.

If your daily check uncovers any items that need attention — repair, replacement, or adjustment — report them promptly. The most minor malfunction could be the result of more serious trouble — or can cause it, if pump is operated. When in doubt, attach an OSHA Lockout/Tagout device tag to the control panel to disconnected electrical power supply at breaker, on electrically driven pumps and disconnect the battery and/or spark plug wire on engine driven pumps.

3

9

# WORK SAFELY — Pumps In General

## SAFE WORKING PROCEDURES

**USE COMMON SENSE!** Most accidents can be avoided by using common sense and concentrating on the job to be done.

**ONLY EXPERIENCED AND QUALIFIED personnel should install and operate pump equipment.**

**KNOW THE PROPER starting procedure for your equipment. Follow the manufacturer's operation manual ... to the letter.**

**DO NOT operate a pump** without all guards and shields in place. (If OSHA required guards are damaged or misplaced, contact the manufacturer for a replacement.)

When **lifting pump** use only lifting equipment in good repair and with adequate capacity. Follow manufacturer's lifting recommendation.

**Check all lubricant levels** before pump installation in accordance with manufacturer's maintenance programs.

**Keep hands and feet clear** of moving parts. DO NOT stick fingers into a pump when in operation. Check suction strainer and hose regularly for proper submergence and to be sure it is free of obstructions.

**NEVER operate** a self-priming pump unless the volute is filled with liquid. The pump will not prime when dry.

**PUMP only liquids** for which the pump has been designed to handle.

**DO NOT** pump flammable, corrosive or caustic materials unless the pump and piping are explicitly designed for that purpose.

**NOTE the direction of rotation** — operation of a pump in the wrong direction can cause the impeller to unscrew and damage the volute case.

**A pump should not be operated against a closed valve or other no flow conditions.** Refer to the pump manufacturer's recommended practice for start-up, operation and shut-down procedures. **DO NOT** close down or restrict a discharge hose. **Be careful** of discharge hose whipping under pressure.

4

## WORK SAFELY – Pumps In General

**MAKE CERTAIN** that whatever is to be connected to the pump is not subjected to pressures greater than those given in the manufacturer's instructions.

**MAKE CERTAIN** all connections are securely made and hoses under pressure are secured, with appropriate safety devices, to prevent whipping.

**BE AWARE OF LIGHTNING.** Stay clear of the pumping equipment during electrical storms. It can attract lightning. (FIG. 10)

### OVERHEATING PRECAUTIONS

**Overheated pumps can cause severe damage** to the equipment and can cause severe physical burns and injury.

**Operating a pump with the suction and/or discharge valve closed** is a principal cause of overheating. Approach cautiously any pump that has been in operation.

**DO NOT remove hoses** from a pump until the system is properly cooled to ambient temperature.

**DO NOT remove the cover plate** or drain plugs from any overheated pump. Allow the pump to cool. Check pump temperature before opening fill port or drain plug.

**If overheating of the pump casing occurs:**

- **STOP** the pump immediately.
- Allow the equipment to **cool completely**.
- Slowly and cautiously **vent the pump**.
- **Refer to the manufacturer's instruction manual** before restarting the unit.
- Remove hoses carefully. Heated water can be in hoses and static head produces pressure.

4

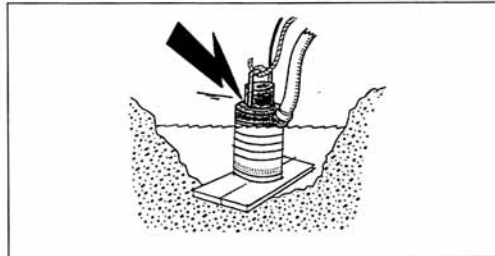

FIG. 10

11

## WORK SAFELY – Pumps In General

### BEFORE STARTING

**Check the pump** thoroughly at delivery for any shipping damage.

**Locate the pump** in an accessible location, as close to the liquid as possible.

**Secure the pump** after it is placed in its intended operating position so it does not tip, roll, slide or fall.

### IMMEDIATELY ON STARTING THE PUMP

Observe gauges, instruments and warning lights to ensure that they are functioning and their readings are within the normal operating range.

- Be sure the immediate work area is safe for operation.
- Operate controls; make certain all operate properly and "feel" right. Accustom yourself to the "feel" of the equipment.
- Listen for any unusual noises, smell for any unusual odors; look for any signs of trouble.
- Be sure to open all manual valves slowly to prevent **WATER HAMMER**.
- Check all warning and safety devices and indicators.

• If safety-related defects or malfunctions are detected, **SHUT DOWN** the equipment. Correct the problem, or notify your supervisor. **DO NOT OPERATE EQUIPMENT WITH DEFECTS OR MALFUNCTIONS UNTIL CORRECTED.**

• **If an unsafe condition cannot be remedied immediately, notify your supervisor and tagout/lockout** the pump on the start switch and/or appropriate, prominent location. (FIG. 11)

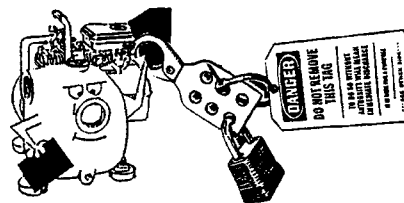

FIG. 11

4

## WORK SAFELY – Engine Driven Pumps

### SAFE WORKING PROCEDURES

#### Do not jump start engine battery.

When operating internal combustion engines in an enclosed area, always make provisions to pipe exhaust fumes to the outside.

**EXHAUST FUMES CAN KILL: Do not operate** engine driven pump equipment in a confined or enclosed space without adequate ventilation.

**Exhaust gases are odorless and deadly poison.**

**DO NOT TOUCH:** The exhaust system components get very hot and stay hot for some time after shutting the engine off.

Follow engine manufacturer's instructions explicitly on hand cranking.

Do not shut down high head pumps quickly:

- A) Throttle back slowly
- B) Open by-pass line
- C) Should have a check valve
- D) Slowly close gate valve on discharge if so equipped.

Check for fuel, oil and hydraulic fluid leaks, worn and damaged hoses/lines or power cables.

### Refueling

When refueling, the following precautions must be followed:

- Add fuel of proper type and grade, only when the pump is not running and engine is cool.
- Fuel in well ventilated area.
- Turn off all electrical switches.
- Keep lighted smoking materials, flames or spark producing devices at a safe distance while refueling.
- Keep fuel nozzle in contact with tank being filled, or provide a ground to prevent static sparks from igniting fuel.
- **Do not spill fuel on hot surfaces.**
- Clean up spillage immediately.
- Do not start engine until fuel cap is secured to the fuel tank.
- **Always** make sure that fuel is being put in the fuel tank, motor oil in the proper location and hydraulic oil into hydraulic oil reservoirs.

5

13

## WORK SAFELY – Engine Driven Pumps

### Maintenance and Repair

All installations, operations and maintenance should be in accordance with pump and engine manufacturer's recommended operation and maintenance program. These manuals should be kept available with the equipment.

Maintenance work can be **hazardous** if not done in a careful manner. All personnel should realize the hazards and strictly follow safe practices.

**NEVER** perform any work on the equipment unless authorized to do so.

**BEFORE ANY** maintenance work is to be done, a LOCKOUT/TAGOUT standard device and procedure should be implemented. Prior to removal of LOCKOUT/TAGOUT, the equipment must be fully operational and all personnel accounted for. Except in cases of emergency, the removal of the LOCKOUT/TAGOUT should be done **ONLY** by the initiating person prior to the return to start-up (see page 12, Fig. 11).

**BEFORE** doing any major work, disconnect the ignition and battery if so equipped.

**Always replace** safety devices removed during service or repair before returning pump to operation.

### Battery Servicing

- **Always wear** safety glasses and gloves when servicing or working with batteries.
- **Before servicing battery**, turn off electrical systems, then disconnect ground terminal clamp. Before installing a battery, turn off electrical equipment, then connect the battery ground clamp **last**.
- **Maintain** electrolyte at the recommended level. Check level frequently. Add distilled water to batteries only when starting up, never when shutting down.
- **Use a flashlight** to check level. **NEVER** use a flame.
- **Do not short** across battery terminals — the spark could ignite the battery gases.

Battery acids will **burn skin**, eat holes in clothing, and can **cause blindness** if splashed in eyes.

**If you spill acid on yourself flush skin immediately with lots of water. Apply baking soda to help neutralize the acid. If acid gets into the eyes, flush immediately with large amounts of water and seek proper medical treatment immediately.**

5

14

## WORK SAFELY – Electric Motor Driven Pumps

### SAFE WORKING PROCEDURES

**Allow only qualified personnel to INSTALL, WIRE AND OPERATE** electric motor driven pumps. Whenever electricity is present there is the possibility of **electrocution**.

**NEVER** use a pump/motor in an explosive atmosphere if it is not exclusively designed for the application.

**Always** ground electrical units.

**Make certain** to connect pump motor to the right phase and voltage.

**Do not** run pump if voltage is not within limits.

**Make sure motor rotation** is in accordance with impeller rotation (which should be indicated somewhere on the pump — check the manufacturer's manual).

**Make all electrical installations** in accordance with National Electric Code, State and Local electrical codes.

**Never use gas piping** as an electrical ground.

**Make sure** the related electrical circuits are dead and locked out before performing any maintenance.

**Follow** motor manufacturer's recommended maintenance and operation instructions.

**If circuit breaker or fuse is tripped**, examine the system for the problem before restarting pump.

**NEVER** use the power cord to aid lifting the pump.

**NEVER** operate a pump with a plug-in type power cord without a ground fault circuit interrupter.

**NEVER** use cords with frayed, cut or brittle insulation. Check the cord on the pump for nicks in the insulation and for sound connections to the ground fault interrupter plug and motor.

**NEVER** let extension cords or the plug connections lay in water. Locate the pump so that the cord cannot fall into any water or be submerged by rising water, unless the pump is designed for such use.

**NEVER** handle energized power cords with wet hands.

**MOTOR OVERLOAD:** do not exceed the manufacturer's recommendation for maximum lift or discharge head. See manufacturer's published curve for proper sizing of motors. A misapplied motor can overheat.

6

15

## WORK SAFELY – Electric Motor Driven Pumps

### Pump Maintenance and Repair

**MAKE SURE** the pump is disconnected from the power source or the appropriate circuits are dead and OSHA Lockout/Tagout is applied before doing any maintenance or repair work on the pump.

Maintenance work can be **hazardous** if not done in a careful manner. All personnel should realize the hazards and strictly follow safe practices.

**NEVER** perform any work on the equipment unless authorized to do so. (FIG. 11) Before performing any maintenance or repair work, consult the manufacturer's instruction manual for recommended procedures.

Pumps with float switches or other automatic devices can start without warning if not properly locked out.

**BEFORE ANY** maintenance work is to be done, a LOCKOUT/TAGOUT standard device and procedure should be implemented. Prior to removal of LOCKOUT/TAGOUT, the equipment must be fully operational and all personnel accounted for. Except in cases of emergency, the removal of the LOCKOUT/TAGOUT should be done **ONLY** by the initiating person prior to the return to start-up.

**ALWAYS** replace safety devices removed during the service or repair before returning pump to operation.

**NEVER** use the power cord to aid in lifting the pump.

### Sizing Extension Cords

Use the following chart to select the correct size extension cord to prevent excessive amperage draw or voltage drop which would cause the motor to overheat. **Cables that are too long or coiled** can cause a voltage drop. **Be aware** that strong sunlight can cause a voltage drop.

Amperes	Wire Gauge and Cord Length (in feet)		
	50	100	150
6	16	16	14
8	16	14	12
10	16	14	12
12	14	14	12
14	14	12	10
16	12	12	10

6

## WORK SAFELY – Submersibles

### SAFE WORKING PROCEDURES

**ALLOW only qualified personnel to INSTALL, WIRE and OPERATE** submersible pumps.

Whenever electricity is present there is the possibility of **electrocution**.

**NEVER** use a pump/motor in an explosive atmosphere, if it is not exclusively designed for that application.

**ALWAYS** ground the pump.

**Make certain to connect the pump to the right phase and voltage.**

**DO NOT** run the pump if voltage is not within limits. **Make all electrical installations** in accordance with National Electric Code, State and Local electrical codes.

**Mount electrical control box** in a vertical position, protected from the elements.

**NEVER** attempt to use the power cord or hydraulic hoses as a lifting or lowering device for submersibles. Attach a lifting cable to the manufacturer's recommended attachment point on the pump for lowering and lifting the pump. (FIG. 12)

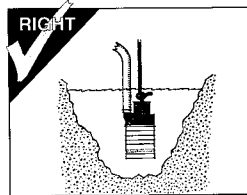

FIG. 12

**NEVER** position the pump directly on a soft, loose bottom. To attain maximum capacity and prevent excessive wear, position the pump so it will not burrow itself into sand or clay. Stand the pump on a plank, a bed of coarse gravel, within a perforated container, on a suitable floatation device, or retain it hanging freely by a lifting cable. (FIG. 13)

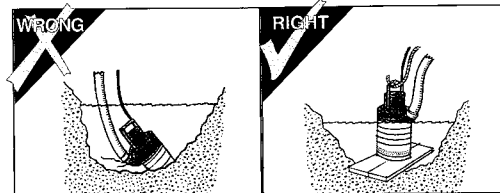

FIG. 13

7

17

## WORK SAFELY – Submersibles

### Pump Maintenance and Repair

**MAKE SURE** the pump is disconnected from the power source or the appropriate circuits are dead and OSHA Lockout/Tagout is applied before doing any maintenance or repair work on the unit.

Maintenance work can be **hazardous** if not done in a careful manner. All personnel should realize the hazards and strictly follow safe practices.

**NEVER** perform any work on the equipment unless authorized to do so. Before performing any maintenance or repair work, consult the manufacturer's instruction manual for recommended procedures.

**BEFORE ANY** maintenance work is to be done, a LOCKOUT/TAGOUT standard device and procedure should be implemented. Prior to removal of LOCKOUT/TAGOUT, the equipment must be fully operational and all personnel accounted for. Except in cases of emergency, the removal of the LOCKOUT/TAGOUT should be done **ONLY** by the initiating person prior to the return to start-up.

**Check oil level ONLY** when pump is cool.

**USE ONLY** recommended oil per manufacturer's recommendation.

**INSPECT ELECTRICAL WIRING** for worn or damaged insulation. **INSTALL** new wiring if wires are damaged. **After repairs are made, clean the equipment before putting the pump back into position.**



7

## TEST YOUR KNOWLEDGE

---

Do you understand this AEM SAFETY MANUAL AND ITEMS SUCH AS ...

- Your safety program?
  - Your pump manufacturer's manual(s)?
  - Proper clothing and personal safety equipment?
  - Your pump's controls, warning signs and devices, and safety equipment?
  - How to properly inspect, mount, and start your pump?
  - How to check your pump for proper operation?
  - Your work area and any special hazards that may exist?
- Proper operating procedures?
  - Proper shutdown procedures?
  - Proper maintenance procedures?
  - Proper loading and unloading procedures for transporting?
  - Under what conditions you should not operate your pump?

**If you do not understand any of these items, consult with your supervisor BEFORE operating your equipment!**

**8**

19

## FINAL WORD TO THE USER

---

Remember that **YOU are the key to safety**. Good safety practices not only protect you but protect the people around you.

You have read this safety manual and the manufacturer's manual(s) for your specific pump. Make them a working part of your safety program. Keep in mind that this safety manual is written for only this type of equipment.

Practice all other usual and customary safe working precautions, and above all —

**REMEMBER  
SAFETY IS UP TO YOU  
YOU CAN PREVENT SERIOUS  
INJURY OR DEATH**

**9**

20

This manual is another in a series on the safe operation of machinery published by AEM.  
For additional publications visit our web site at [www.aem.org](http://www.aem.org).



**Association of Equipment Manufacturers**

Toll free 1-866-AEM-0442

e-mail [aem@aem.org](mailto:aem@aem.org)

[www.aem.org](http://www.aem.org)





## EC DECLARATION OF CONFORMITY

WACKER NEUSON CORPORATION, N92W15000 ANTHONY AVENUE, MENOMONEE FALLS, WISCONSIN USA

AUTHORIZED REPRESENTATIVE IN THE EUROPEAN UNION	<b>Axel Häret WACKER NEUSON SE Preußenstraße 41 80809 München</b>
---	---

hereby certifies that the construction equipment specified hereunder:

- Category:  
**Centrifugal Trash Pump**
- Machine function:  
**This machine is a centrifugal trash pump intended to be used for general de-watering applications.**
- Type / Model  
**Pump PT 2, PT 2A, PT 2H**
- Item number of equipment:  
**0009095, 0009097, 0009237, 0620725**
- Net installed power:  
**PT 2 4,2 kW  
PT 2A 3,6 kW  
PT 2H 3,4 kW**

Has been sound tested per Directive 2000/14/EC:

Conformity Assessment Procedure	Measured sound power level	Guaranteed sound power level
<b>ANNEX V</b>	<b>PT 2 100 dB(A) PT 2A 101 dB(A) PT 2H 107 dB(A)</b>	<b>PT 2 101 dB(A) PT 2A 102 dB(A) PT 2H 107 dB(A)</b>

- This machinery fulfills the relevant provisions of Machinery Directive 2006/42/EC and is also produced in accordance with these standards:  
**2000/14/EC  
2002/88/EC  
89/336/EC  
98/37/EEC**

18.12.09

Date

William Lahner  
Vice President of Engineering

Dan Domanski  
Manager, Product Engineering

**WACKER NEUSON CORPORATION**

*The original language of this EC Declaration of Conformity is American English.*

